



מפוחים רגנרטיביים וסכיני אוויר



AMS
פתרונות הולכה וסינון אוויר

מפוחים ומערכות סכיני אוויר

- תהליכי ניגוב, ייבוש וניקוי באוויר, הם תהליכים שכיחים בתעשייה, לרוב עדיין נעשה שימוש באוויר דחוס שהיינו משאב יקר למרות שאין צורך בלחץ העבודה הנבנה במדחס.
- צריכת האנרגיה של מפוח רגנטיבי נמוכה עד פי 3.5 בהשוואה לשימוש באוויר דחוס!
- בנוסף המפוחים משמשים עבור כל המערכות שנדרש בהן לחץ אוויר הניתן לשימוש ע"י מפוח ומערכות שאיבה כגון:
 - יניקה מערכות חיתוך וניקוב, מערכות סינון, ניגוב בתעשיית הנייר, שינוע בוואקום, שינוע אבקות, אוורור מכלי ומאגרי מים ועוד.
 - אנו מציעים מפוחים רגנטיבים המפתחים לחץ עד 780 mbar ומגוון סכיני אוויר, בנוסף אנו מציעים ייעוץ למערכות הכולל אפיון טכנו-כלכלי ומתן חלופה אופטימאלית, קיימת אופציה לתכנון ובניית מתקנים לפי דרישה.

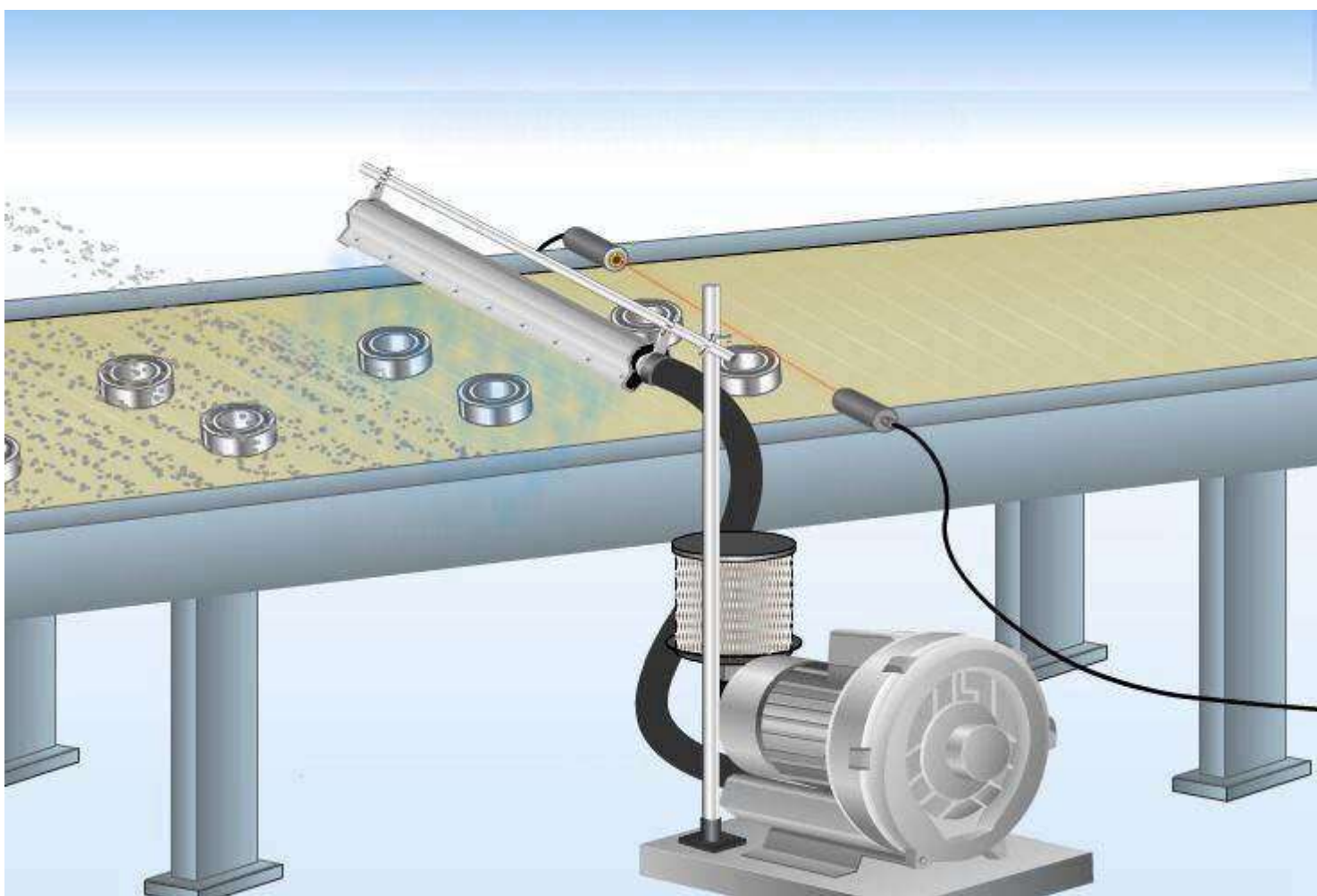

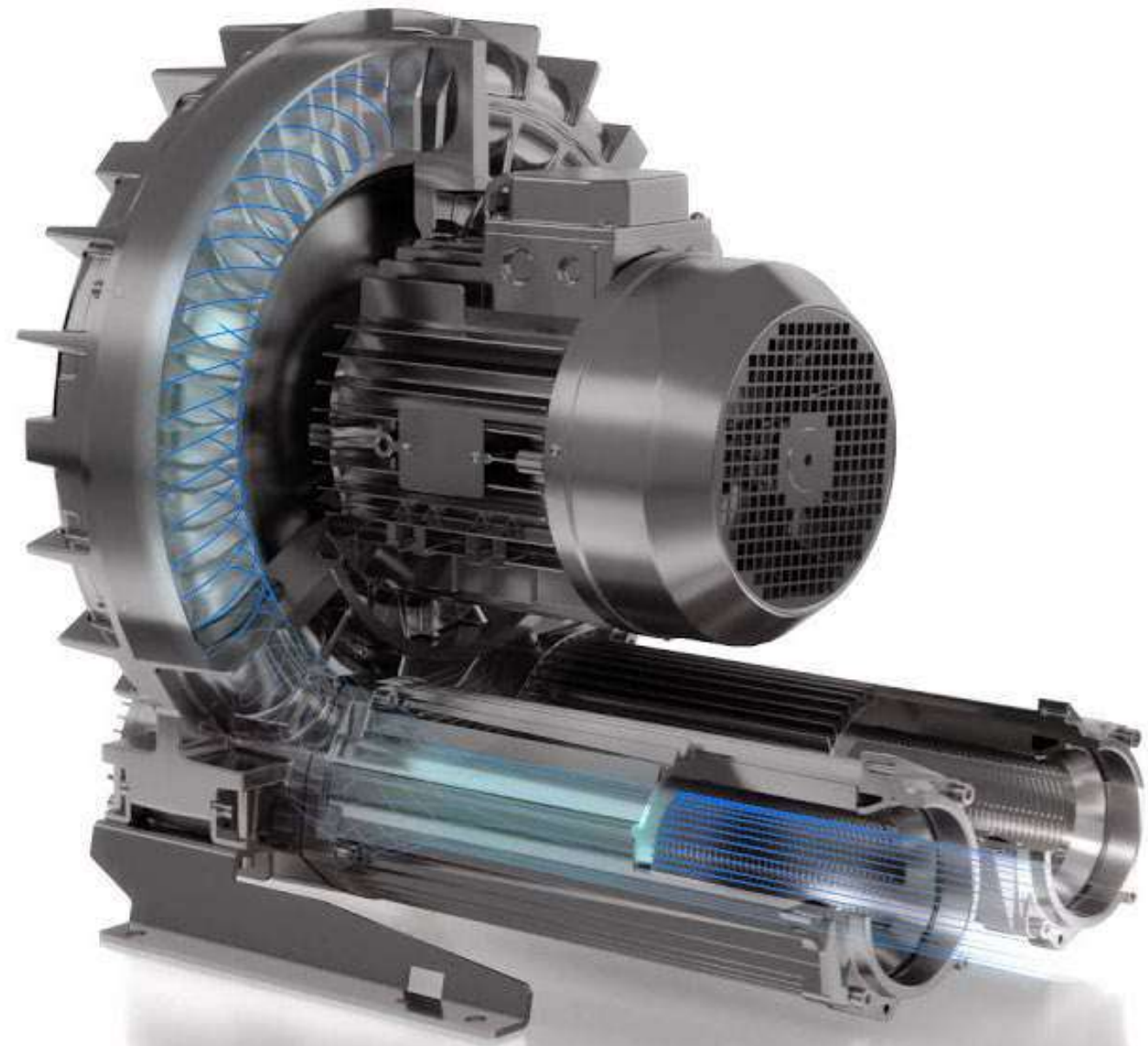

מאפיינים

- משאבת ואקום ללא שמן מבנה סגסוגת אלומיניום
- חד או דו דרגתי
- הספק 0.37-29 kw
- ספיקות אוויר 80-2500 מקל"ש
- לחץ 780 MBAR

אופציות

- מסנן אבק בפתח יניקה
- משתיקי קול
- שסתומי פריקת לחץ
- מוגן פיצוץ וניצוץ תקן ATEX

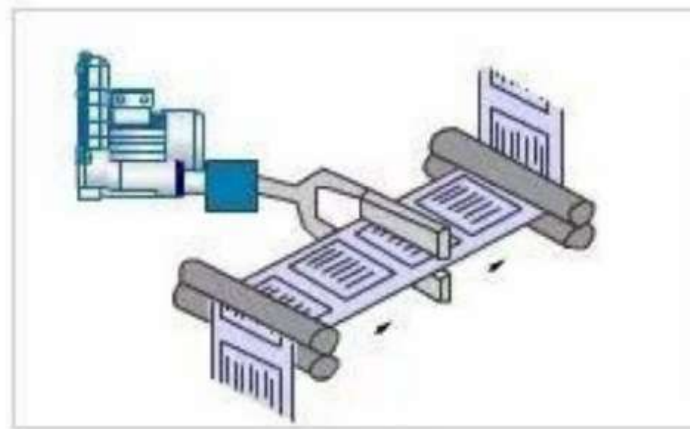

מערכות סכיני אוויר

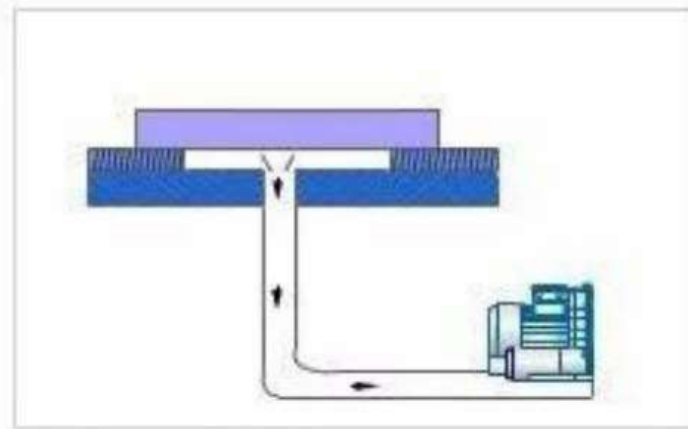

יצור

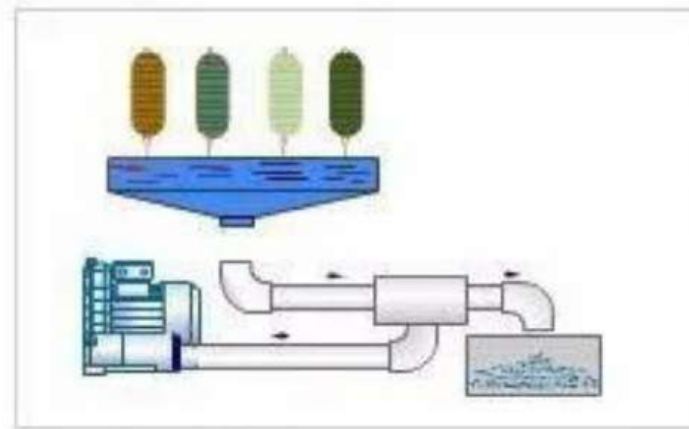

טקסטיל

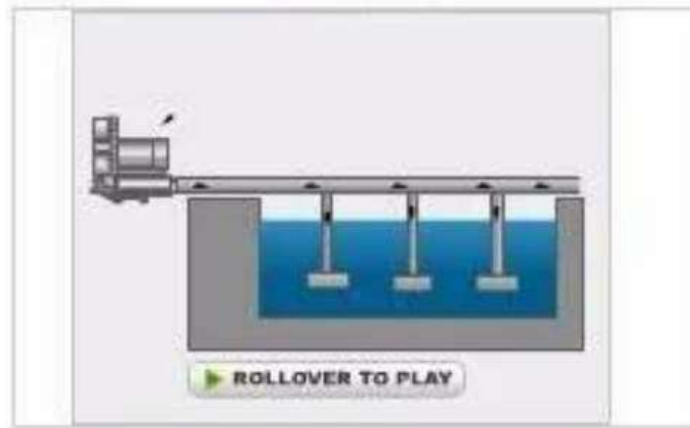

חימצון

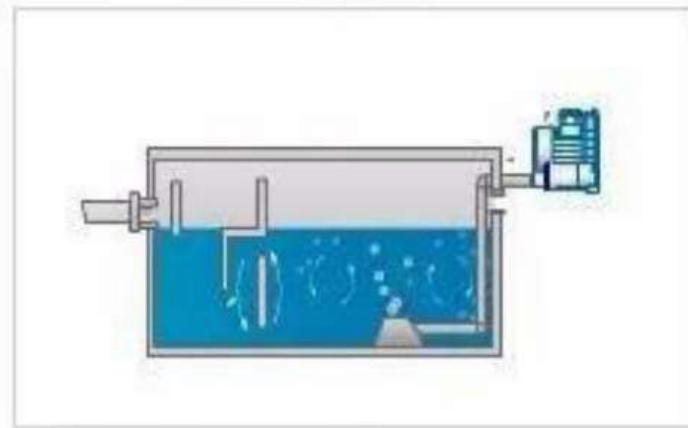

טיפול בבוצה

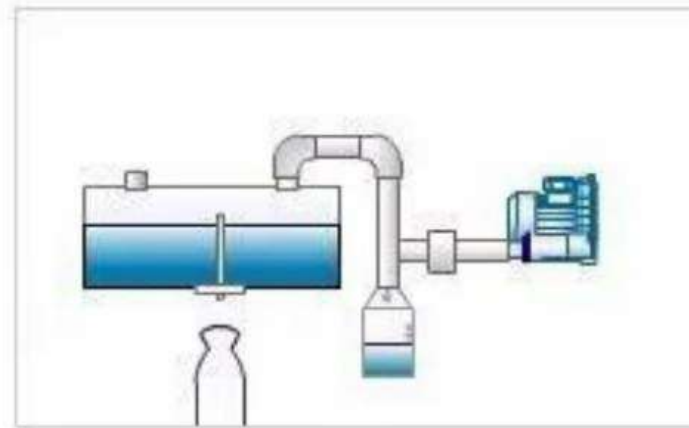

מילוי נוזלים

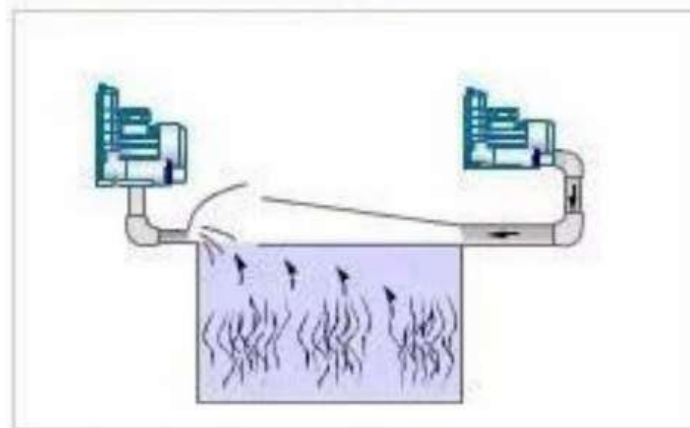

טיפול בעשן



אתרי עבודה

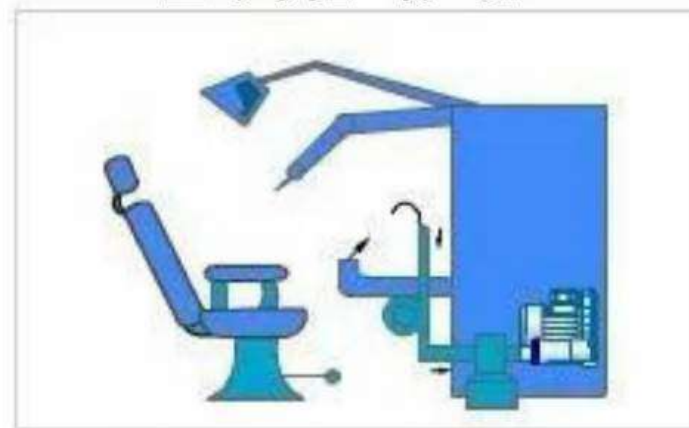

רפואת שיניים

שימוש

Selection and ordering data for side channel blowers in vacuum and pressure operation.



single-phase blower

Order Number	Frequency Hz	MOTOR			Weight Kg	Sound db(A)	Normal airflow m ³ /h	Normalvacuum mbar	Normal pressure mbar	Discharging valve/ filter
		Output k:W	Rated Voltage V	Current A						
2MV210A11	50	0.37	220	2.7	11	53	80	-110	110	RV-01/MF-10
	60	0.45	220	3.0		56	96	-130	140	RV-01/MF-10
2MV 230 A11	50	0.37	220	2.7	11	54	100	-110	110	RV-01/MF-10
	60	0.45	220	3.0		57	120	-130	140	RV-01/MF-10
2MV 310 A01	50	0.55	220	3.7	13	55	100	-120	120	RV-01/MF-10
	60	0.62	220	4.5		57	120	-130	150	RV-01/MF-10
2MV310A11	50	0.7	220	4.8	14	55	100	-150	150	RV-01/MF-10
	60	0.8	220	4.1		57	120	-150	160	RV-01/MF-10
2MV 320 A31	50	1.1	220	7.3	17	58	120	-240	280	RV-01/MF-10
	60	1.3	220	8.3		60	145	-230	250	RV-01/MF-10
2MV410A11	50	0.8	220	5.2	15	63	145	-150	160	RV-01/MF-12
	60	0.9	220	5.8		64	175	-160	140	RV-01/MF-12
2MV410A21	50	1.1	220	7.3	16	63	145	-150	190	RV-01/MF-12
	60	1.3	220	8.3		64	175	-180	190	RV-01/MF-12
2MV420A11	50	1.5	220	9	26	66	150	-280	290	RV-01/MF-12
	60	1.75	220	10		69	180	-250	280	RV-01/MF-12
2MV 430 A11	50	0.8	220	5.2	16	64	180	-100	110	RV-01/MF-12
	60	0.9	220	5.8		66	210	-100	110	RV-01/MF-12
2MV 430 A21	50	1.1	220	7.3	17	64	180	-170	210	RV-01/MF-12
	60	1.3	220	8.3		66	210	-145	145	RV-01/MF-12
2MV510A11	50	1.1	220	7.3	21	64	210	-160	160	RV-01/MF-16
	60	1.3	220	8.3		70	255	-150	160	RV-01/MF-16
2MV 510 A21	50	1.5	220	9	24	64	210	-190	200	RV-01/MF-16
	60	1.75	220	10		70	255	-180	180	RV-01/MF-16
2MV 530 A21	50	1.5	220	9	26	65	270	-140	120	RV-01/MF-16
	60	1.75	220	10		71	330	-110	100	RV-01/MF-16
2MV610A11	50	2.2	220	10	30	64	270	-230	250	RV-01/MF-16
	60	2.55	220	11		70	315	-250	270	RV-01/MF-16
2MV710A11	50	2.2	220	12.8	30	72	318	-190	190	RV-01/MF-16
	60	2.55	220	12.8		74	376	-190	200	RV-01/MF-16

2MV series Selection diagram 50/60Hz difference

The performance curves of Manvac blower is tested through below ways: Under one atmospheric pressure suck 15°C air and then you can calculate the data of course allow 10% ,and when the sucked air and surrounding stempere are not higher than 25°C, you still can get total pressure difference as the curves shows.

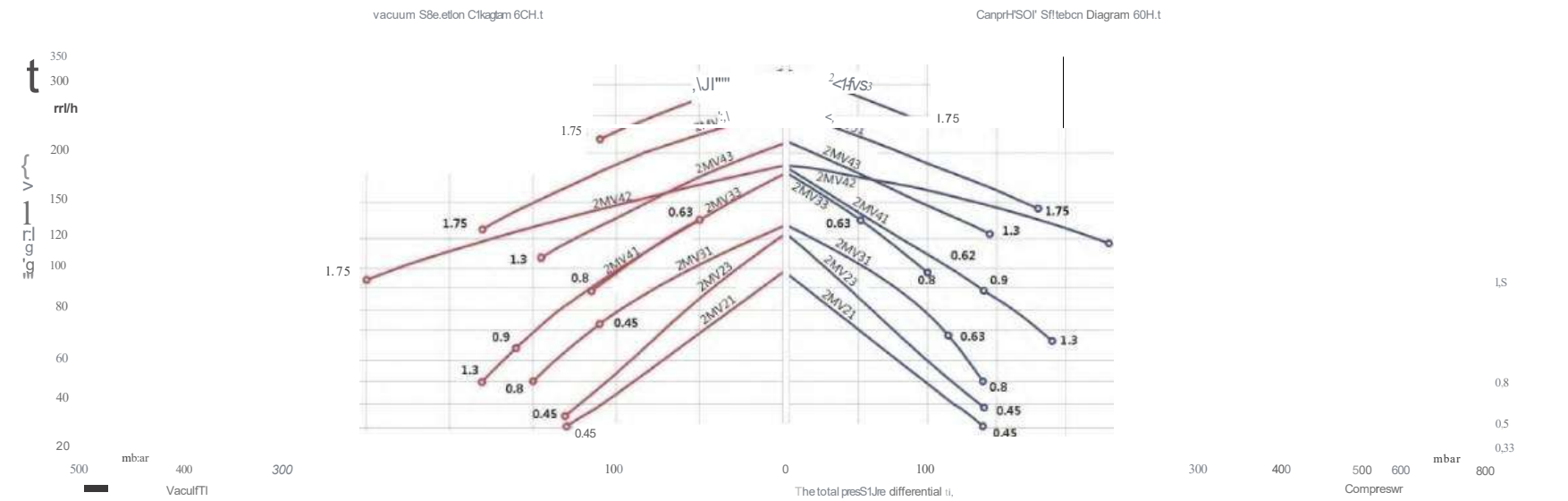
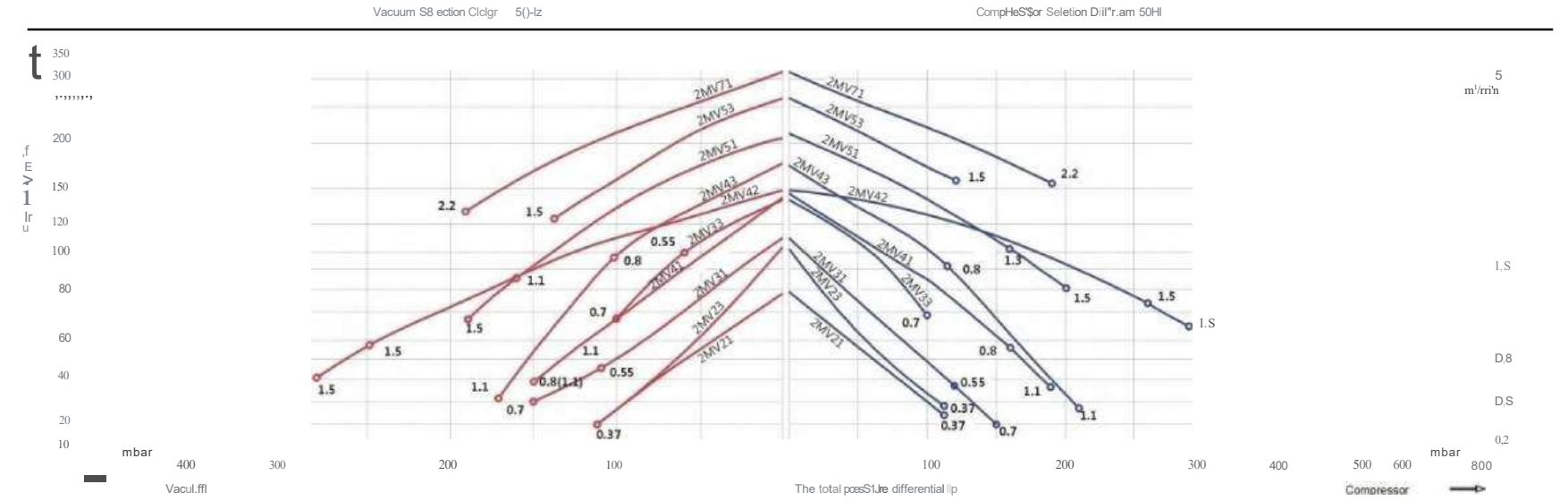

Selection and ordering data for side channel blowers in vacuum and pressure operation.

Three-phase blower

Order Number	Frequency Hz	MOTOR			Weight Kg	Sound db(A)	Normal airflow m ³ /h	Normal vacuum mbar	Normal pressure mbar	Discharging valve/ filter
		Rated								
		Output KW	Voltage V	Current A						
2MV 210 H16	50	0.4	200-240Δ/345-415Y	2.6Δ/1.5Y	10	53	80	-120	130	RV-01/MF-10
	60	0.5	220-275Δ/380-480Y	2.6Δ/1.5Y		56	98	-150	160	RV-01/MF-10

2MV series Selection diagram 50/60Hz difference

The performance curves of Manvac blower is tested through below ways: Under one atmospheric pressure suck 15°C air and then you can calculate the data of course allow 10% ,and when the sucked air and surrounding stempere are not higher than 25°C, you still can get total pressure difference as the curves shows.

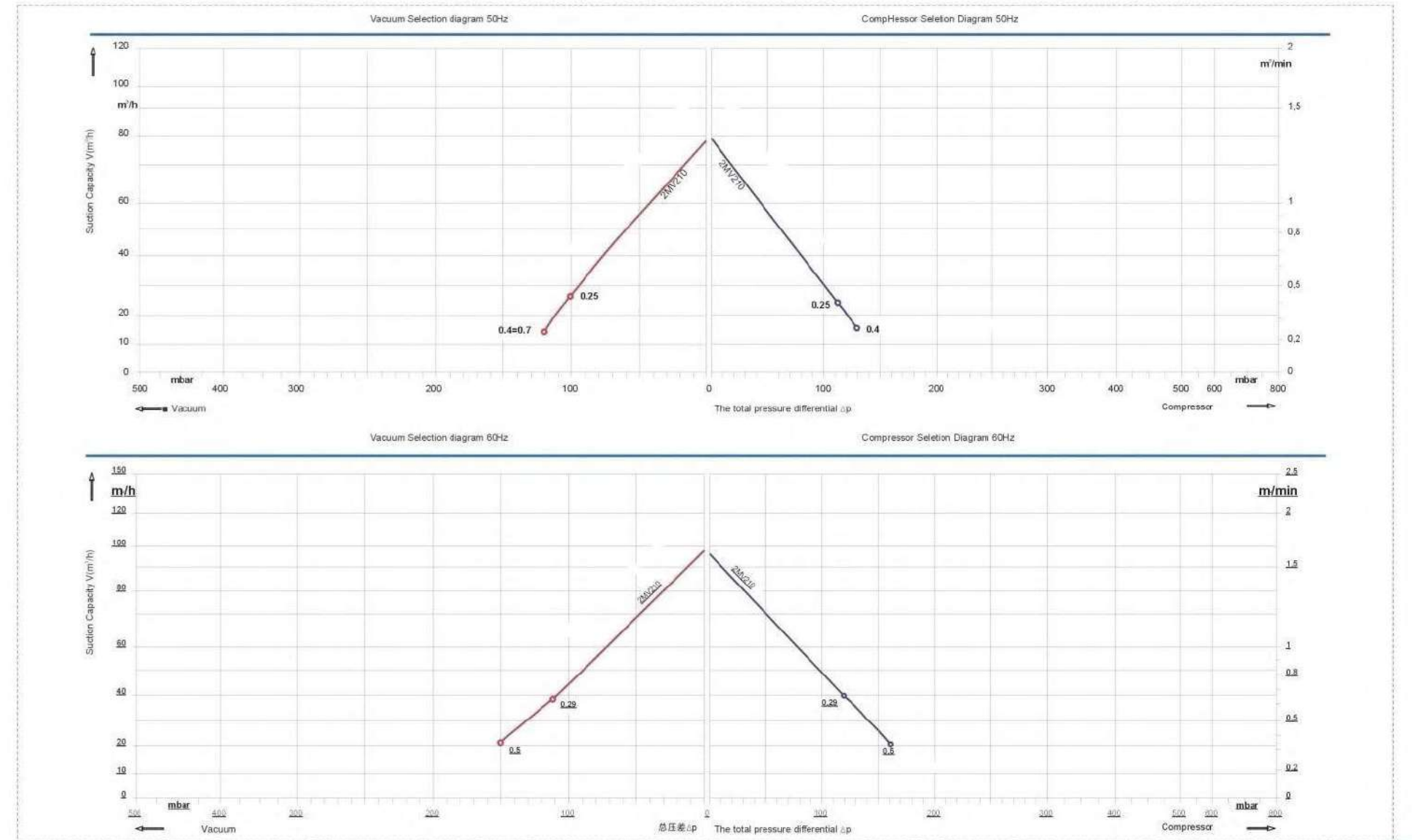

Selection and ordering data for side channel blowers in vacuum and pressure operation.

Three-phase blower

Order Number	Frequency	MOTOR			Weight	Sound	Normal airflow	Normal vacuum	Normal pressure	Discharging valve/ filter
		Rated								
		Output	Voltage	Current						
Hz	KW	V	A	Kg	db(A)	m ³ /h	mbar	mbar		
2MV 310 H06	50	0.55	200-240A/345-415Y	2.86./1.6Y	11	55	100	-110	120	RV-01/MF-10
	60	0.63	220-275A/380-480Y	3.06./1.7Y		57	120	-110	120	RV-01/MF-10
2MV310H16	50	0.75	200-240A/345-415Y	3.86./2.2Y	12	55	100	-150	150	RV-01/MF-10
	60	0.83	220-275A/380-480Y	3.8t../2.2Y		57	120	-150	140	RV-01/MF-10
2MV 320 H26	SO	0.85	200-240A/345-415Y	4.2t../2.4Y	17	58	110	-200	230	RV-01/MF-10
	60	0.95	220-275A/380-480Y	4.06./2.3Y		60	130	-240	240	RV-01/MF-10
2MV 320 H36	50	1.3	200-240A/345-415Y	5.7 t../3.3Y	18	58	110	-280	290	RV-01/MF-10
	60	1.5	220-275A/380-480Y	6.0t../3.5Y		60	130	-300	400	RV-01/MF-10
2MV 330 H16	SO	0.55	200-240A/345-415Y	2.86./1.6Y	12	56	140	-60	60	RV-01/MF-10
	60	0.63	220-275A/380-480Y	3.06./1.7Y		58	165	-50	50	RV-01/MF-10
2MV330H26	50	0.75	200-240A/345-415Y	3.8t../2.2Y	13	56	140	-100	100	RV-01/MF-10
	60	0.83	220-275A/380-480Y	3.8t../2.2Y		58	165	-115	100	RV-01/MF-10

2MV series Selection diagram 50/60Hz difference

The performance curves of Manvac blower is tested through below ways:
Under one atmospheric pressure suck 15°C air and then you can calculate the data of course allow 10% ,and when the sucked air and surrounding temperature are not higher than 25°C, you still can get total pressure difference as the curves shows.

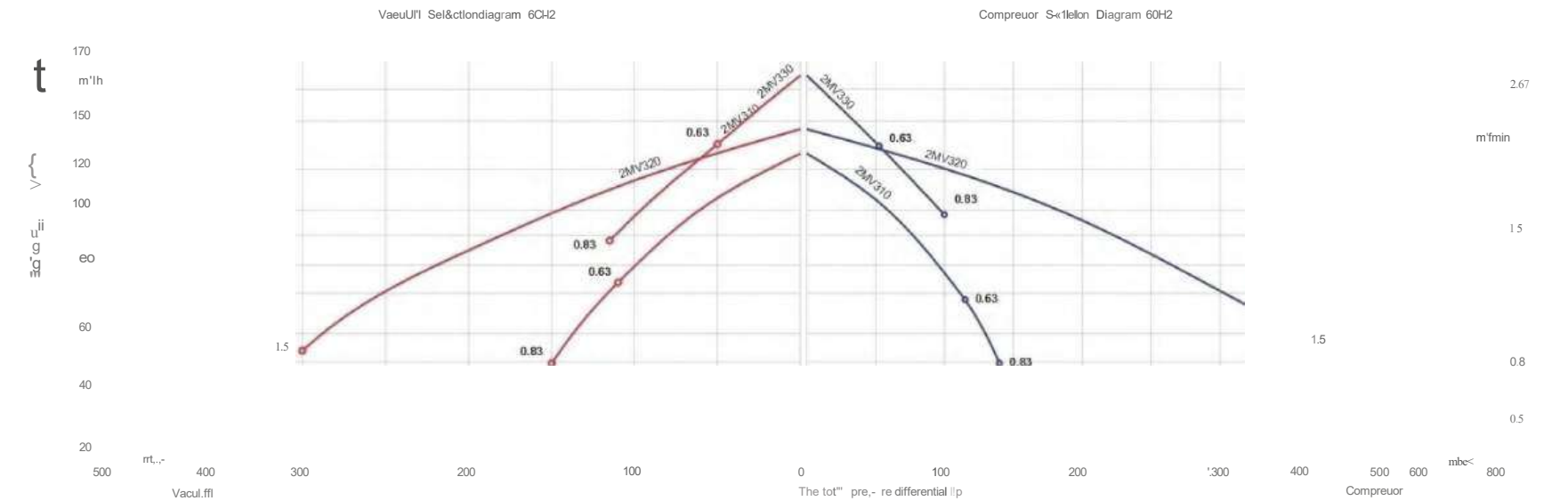
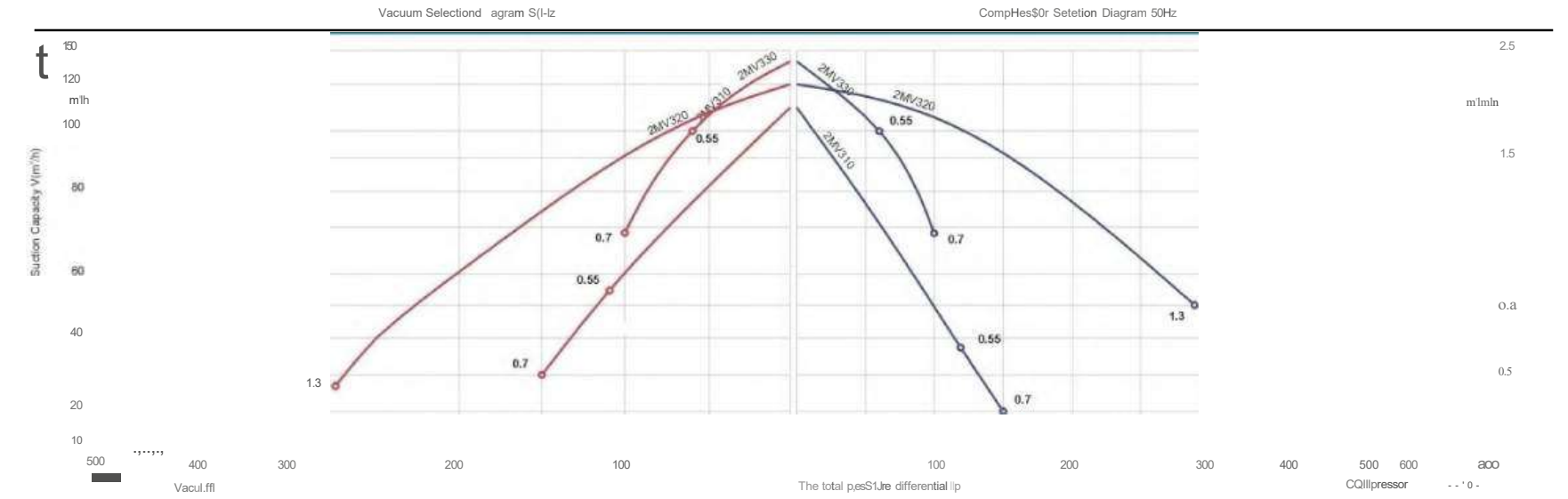

Selection and ordering data for side channel blowers in vacuum and pressure operation. Three-phase blower

Order Number	Frequency Hz	MOTOR			Weight Kg	Sound db(A)	Normal airflow m ³ /h	Normal vacuum mbar	Normal pressure mbar	Discharging valve/ filter
		Rated		Current A						
		Power KW	Voltage V							
2MV 410 H06	50	0.7	200-2406/345-415Y	3.8E!./2.2Y	13	63	145	-120	120	RV-01/MF-12
	60	0.83	220-2756/380-480Y	3.7St!./2.15Y		64	175	-130	130	RV-01/MF-12
2MV410H16	50	0.85	200-2406/345-415Y	4.0t!./2.3Y	16	63	145	-160	160	RV-01/MF-12
	60	0.95	220-2756/380-480Y	3.85t!./2.25Y		64	175	-160	160	RV-01/MF-12
2MV 410 H26	50	1.3	200-2406/345-415Y	5.7 t!./3.3Y	17	63	145	-170	200	RV-01/MF-12
	60	1.5	220-2756/380-480Y	6.0!./3.5Y		64	175	-210	220	RV-01/MF-12
2MV 420 H36	50	1.6	200-2406/345-415Y	7.5!./4.3Y	25	66	150	-280	280	RV-01/MF-12
	60	2.05	220-2756/380-480Y	7.6t!./4.4Y		69	180	-320	310	RV-01/MF-12
2MV 420 H46	50	2.2	200-2406/345-415Y	9.7 t!./5.6Y	27	66	150	-330	440	RV-02/MF-12
	60	2.55	220-2756/380-480Y	10.0!./5.8Y		69	180	-350	420	RV-02/MF-12

2MV series Selection diagram 50/60Hz difference

The performance curves of Manvac blower is tested through below ways: Under one atmospheric pressure suck 15°C air and then you can calculate the data of course allow 10% ,and when the sucked air and surrounding stempera ture are not higher than 25°C, you still can get total pressure difference as the curves shows.

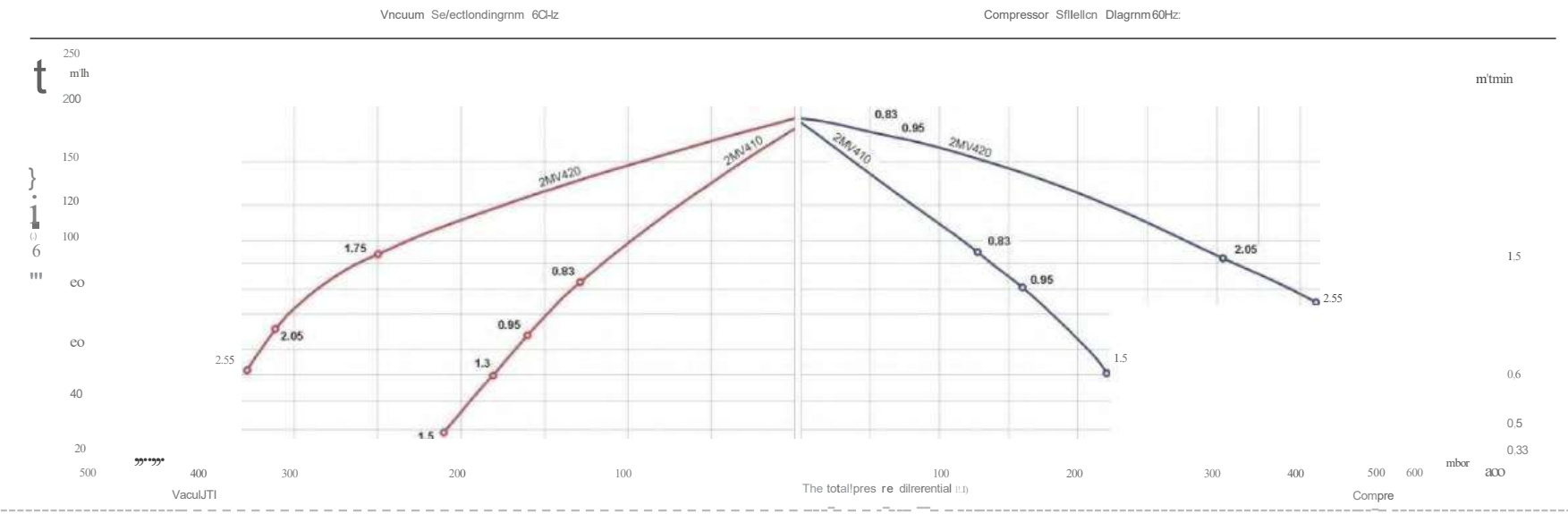
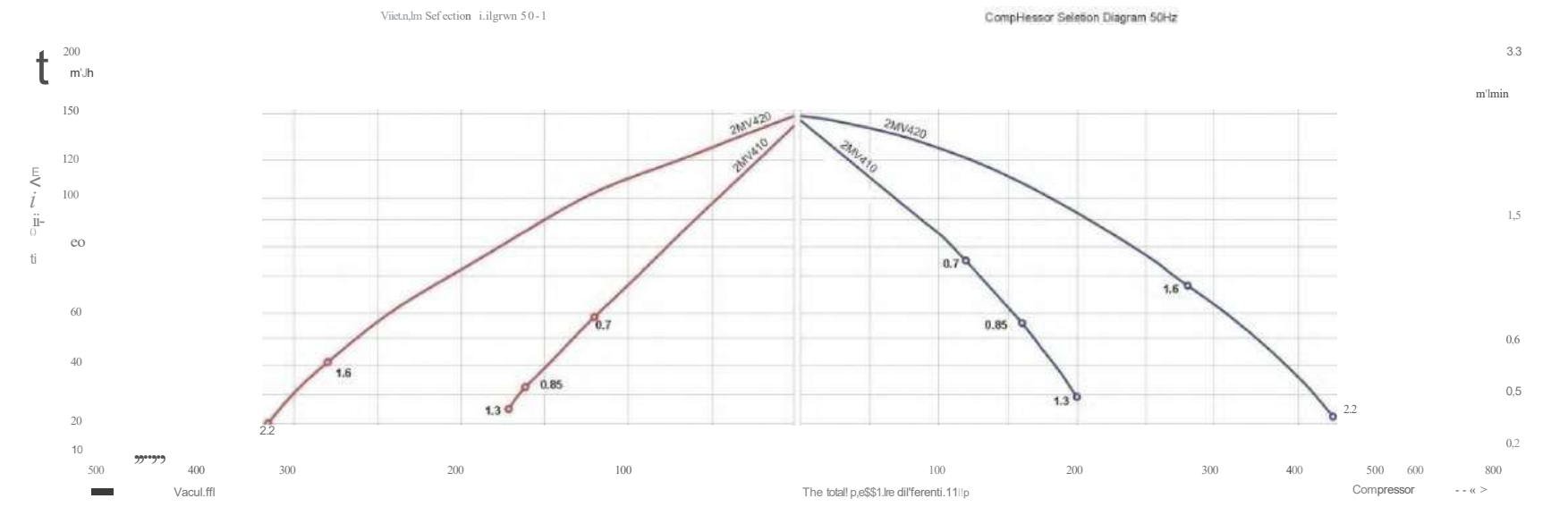

Selection and ordering data for side channel blowers in vacuum and pressure operation.

Three-phase blower

Order Number	Frequency	MOTOR			Weight	Sound	Normal airflow	Normal vacuum	Normal pressure	Discharging valve/ filter
		Rated		Current						
		Power	Voltage							
Hz	KW	V	A	Kg	db(A)	m ³ /h	mbar	mbar		
2MV 510 H06	50	0.85	200-240 li./345-415Y	4.06./2.3V	20	64	210	-110	100	RV-01/MF-16
	60	0.95	220-275 li./380-480Y	4.26./2.3V		70	255	-80	70	RV-01/MF-16
2MV 510 H16	50	1.3	200-240 ti./345-415Y	6.66./3.8Y	22	64	210	-170	170	RV-01/MF-16
	60	1.5	220-275 li./380-480Y	6.96./4.0Y		70	255	-150	140	RV-01/MF-16
2MV 510 H26	50	1.6	200-240 li./345-415Y	7.5b./4.3Y	23	64	210	-200	190	RV-01/MF-16
	60	2.05	220-275 li./380-480Y	7.6b./4.4Y		70	255	-220	210	RV-01/MF-16
2MV 510 H36	50	2.2	200-240 li./345-415Y	9.7 6./5.6Y	25	64	210	-220	270	RV-01/MF-16
	60	2.55	220-275 li./380-480Y	10.3b./6.0Y		70	255	-260	290	RV-01/MF-16
2MV 520 H46	50	3.0	200-240 li./345-415Y	12.5A/7.2Y	40	72	230	-340	410	RV-02/MF-16
	60	3.45	220-275 ti./380-480Y	12.6 b./7.3Y		74	275	-380	360	RV-02/MF-16
2MV 520 H57	50	4.0	345-415 li./600-720Y	10.06./5.BY	44	72	230	-390	490	RV-02/MF-16
	60	4.6	380-480 li./660-720Y	9.9b./5.7Y		74	275	-410	480	RV-02/MF-16
2MV 530 H06	50	0.85	200-2406/345-415Y	4.0D./2.3Y	21	65	270	-40	40	RV-01/MF-16
	60	0.95	220-275 ti./380-480Y	4.2D./2.4Y		71	330	-40	40	RV-01/MF-16
2MV 530 H16	SO	1.3	200-2406/345-415Y	6.6D./3.8Y	23	65	270	-100	100	RV-01/MF-16
	60	1.5	220-275 li./380-480Y	6.96./4.0Y		71	330	-70	50	RV-01/MF-16
2MV 530 H26	50	1.6	200-2406/345-415Y	7.5D./4.3Y	24	65	270	-150	150	RV-01/MF-16
	60	2.05	220-275 6/380-480Y	7.6D./4.4Y		71	330	-150	130	RV-01/MF-16
2MV 530 H36	50	2.2	200-240 ti./345-415Y	9.7 6./5.6Y	26	65	270	-220	230	RV-01/MF-16
	60	2.55	220-275 ti./380-480Y	10.36./6.0Y		71	330	-230	210	RV-01/MF-16

2MV series Selection diagram 50/60Hz difference

The performance curves of Manvac blower is tested through below ways: Under one atmospheric pressure suck 15°C air and then you can calculate the data of course allow 10% ,and when the sucked air and surrounding stempera ture are not higher than 25°C, you still can get total pressure difference as the curves shows.

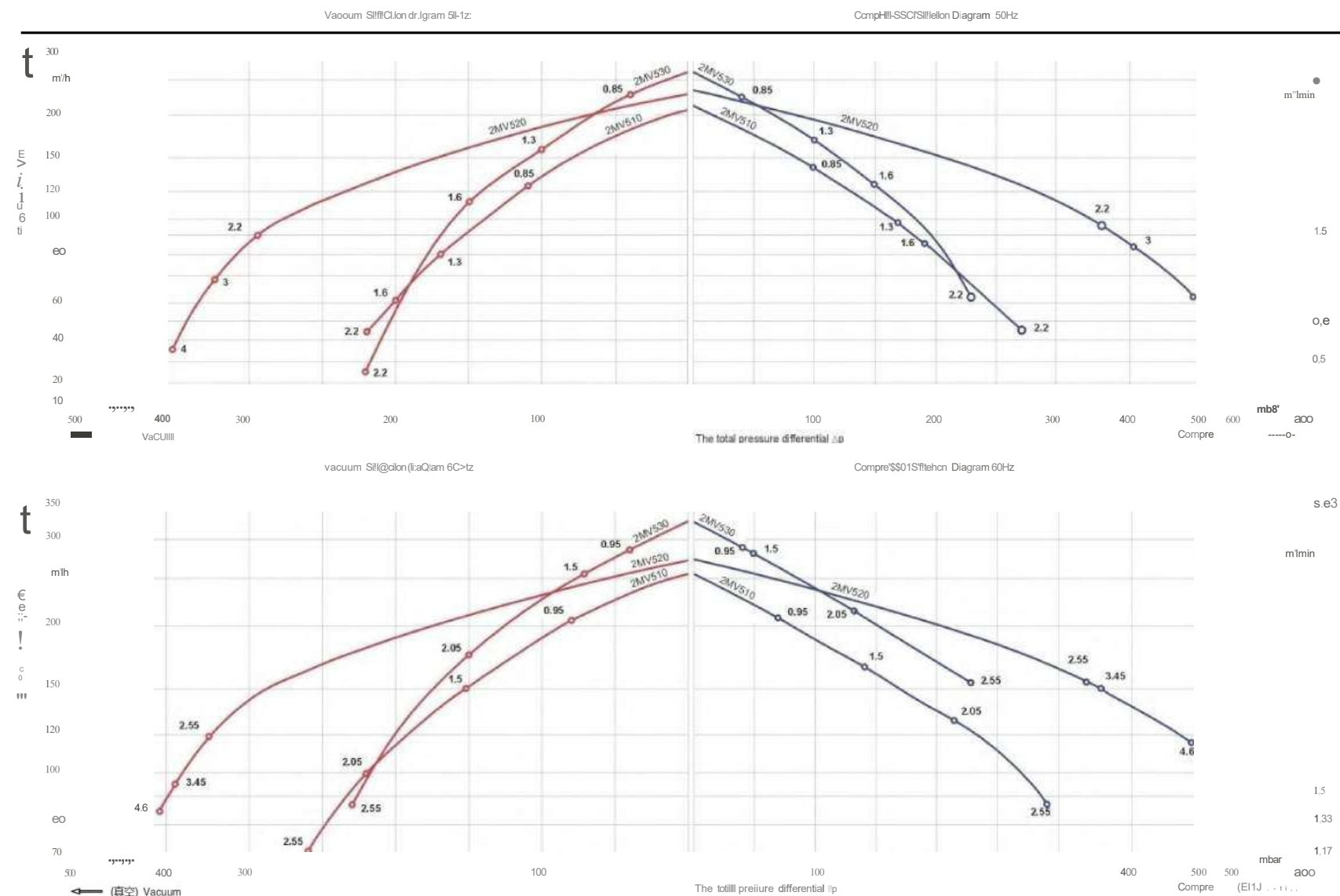

Selection and ordering data for side channel blowers in vacuum and pressure operation.

Three-phase blower

Order Number	Frequency	MOTOR			Weight	Sound	Normal airflow	Normal vacuum	Normal pressure	Discharging valve/ filter
		Rated								
		Power	Voltage	Current						
KW	V	A	Kg	db(A)	m ³ /h	mbar	mbar			
2MV 610 H06	50	1.6	200-240 /345-415V	8.56./4.9Y	25	68	265	-170	180	RV-01/MF-16
	60	2.05	220-275 /380-480V	8.86./5.1Y		70	315	-180	190	RV-01/MF-16
2MV610H16	50	2.2	200-240 /345-415V	9.76./5.6Y	28	69	265	-235	220	RV-01/MF-16
	60	2.55	220-275 /380-480V	10.36./6.0Y		72	315	-245	230	RV-01/MF-16
2MV 610 H26	50	3.0	200-240 /345-415V	12.56./7.2Y	34	69	265	-280	280	RV-01/MF-16
	60	3.45	220-275 /380-480V	12.66./7.3Y		72	315	-260	270	RV-01/MF-16

2MV series Selection diagram 50/60Hz difference

The performance curves of Manvac blower is tested through below ways:
Under one atmospheric pressure suck 15°C air and then you can calculate the data of course allow 10% ,and when the sucked air and surrounding stempera ture are not higher than 25°C, you still can get total pressure difference as the curves shows.

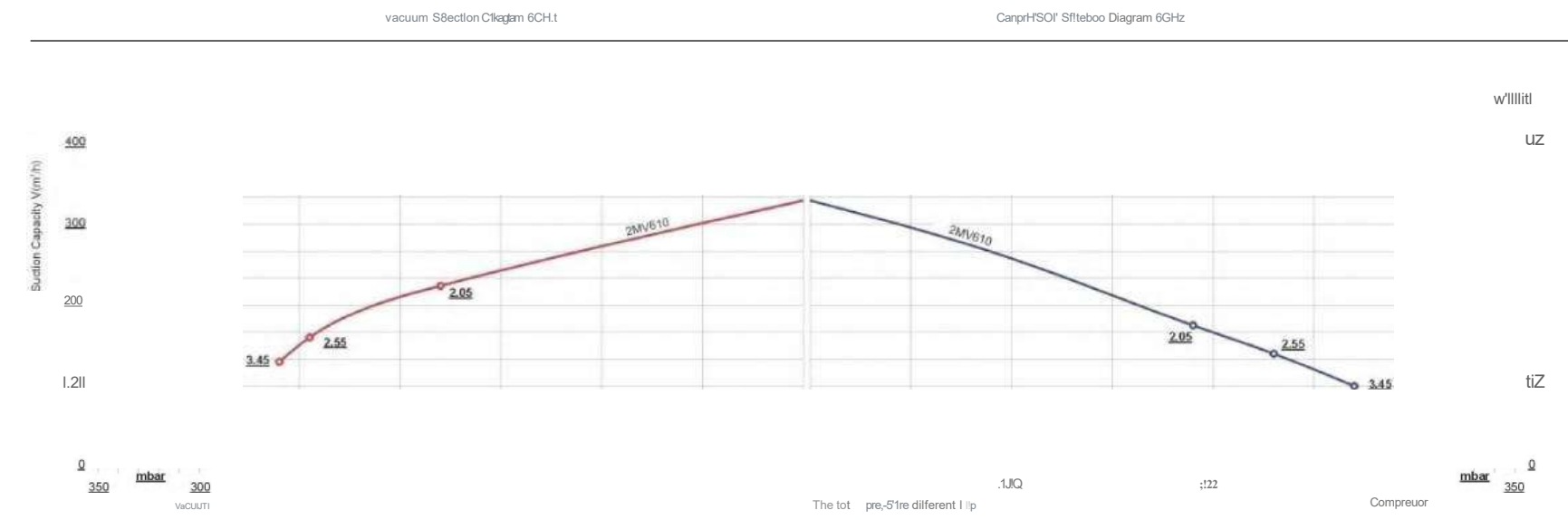
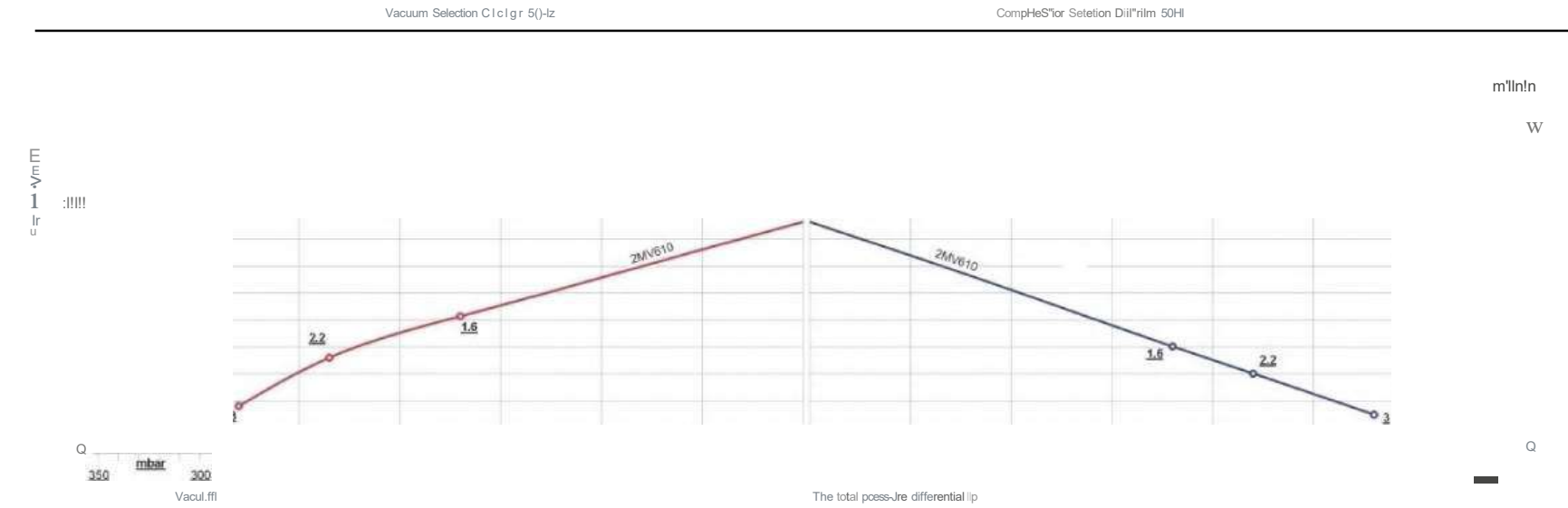

Selection and ordering data for side channel blowers in vacuum and pressure operation.

Three-phase blower

Order Number	Frequency Hz	MOTOR			Weight Kg	Sound db(A)	Normal airflow m ³ /h	Normal vacuum mbar	Normal pressure mbar	Discharging valve/ filter
		Output KW	Rated							
			Voltage V	Current A						
2MV 710 H06	50	1.6	200-240Δ/345-415Y	8.5Δ/4.9Y	27	69	318	-160	150	RV-01/MF-16
	60	2.05	220-275Δ/380-480Y	8.8Δ/5.1Y		72	376	-160	150	RV-01/MF-16
2MV 710 H16	50	2.2	200-240Δ/345-415Y	9.7Δ/5.6Y	30	69	318	-210	200	RV-01/MF-16
	60	2.55	220-275Δ/380-480Y	10.3Δ/6.0Y		72	376	-210	200	RV-01/MF-16
2MV 710 H26	50	3.0	200-240Δ/345-415Y	12.5Δ/7.2Y	36	69	318	-270	290	RV-01/MF-16
	60	3.45	220-275Δ/380-480Y	12.6Δ/7.3Y		72	376	-250	230	RV-01/MF-16
2MV 710 H37	50	4.0	345-415Δ/600-720Y	9.0Δ/5.2Y	40	69	318	-290	330	RV-01/MF-16
	60	4.6	380-480Δ/660-720Y	9.0Δ/5.2Y		72	376	-230	330	RV-01/MF-16
2MV 720 H16	50	2.2	200-240Δ/345-415Y	9.7Δ/5.6Y	43	73	320	-220	210	RV-01/MF-16
	60	2.55	220-275Δ/380-480Y	10.3Δ/6.0Y		76	380	-170	150	RV-01/MF-16
2MV 720 H26	50	3.0	200-240Δ/345-415Y	12.5Δ/7.2Y	48	73	320	-280	260	RV-01/MF-16
	60	3.45	220-275Δ/380-480Y	12.6Δ/7.3Y		76	380	-230	200	RV-01/MF-16
2MV 720 H37	50	4.3	345-415Δ/600-720Y	10.0Δ/5.2Y	54	73	320	-360	380	RV-02/MF-16
	60	4.8	380-480Δ/660-720Y	10.4Δ/6.0Y		76	380	-350	320	RV-02/MF-16
2MV 720 H47	50	5.5	345-415Δ/600-720Y	13.3Δ/7.7Y	66	73	320	-440	500	RV-02/MF-16
	60	6.3	380-480Δ/660-720Y	13.3Δ/7.7Y		76	380	-440	500	RV-02/MF-16
2MV 720 H57	50	7.5	345-415Δ/600-720Y	16.7Δ/9.6Y	73	73	320	-440	570	RV-02/MF-16
	60	8.6	380-480Δ/660-720Y	17.3Δ/10.0Y		76	380	-460	660	RV-02/MF-16
2MV 730 H06	50	1.6	200-240Δ/345-415Y	8.5Δ/4.9Y	29	70	420	-100	100	RV-01/MF-16
	60	2.05	220-275Δ/380-480Y	8.8Δ/5.1Y		73	500	-110	80	RV-01/MF-16
2MV 730 H16	50	2.2	200-240Δ/345-415Y	9.7Δ/5.6Y	32	70	420	-170	170	RV-01/MF-16
	60	2.55	220-275Δ/380-480Y	10.3Δ/6.0Y		73	500	-160	120	RV-01/MF-16
2MV 730 H26	50	3.0	200-240Δ/345-415Y	12.5Δ/7.2Y	37	70	420	-220	220	RV-01/MF-16
	60	3.45	220-275Δ/380-480Y	12.6Δ/7.3Y		73	500	-200	190	RV-01/MF-16
2MV 730 H37	50	4.0	345-415Δ/600-720Y	9.0Δ/5.2Y	43	70	420	-260	310	RV-01/MF-16
	60	4.6	380-480Δ/660-720Y	9.0Δ/5.2Y		73	500	-260	280	RV-01/MF-16
2MV 740 H37	50	4.0	345-415Δ/600-720Y	9.0Δ/5.2Y	54	74	500	-150	140	RV-01/MF-16
	60	4.6	380-480Δ/660-720Y	9.0Δ/5.2Y		78	600	-100	90	RV-01/MF-16
2MV 740 H47	50	5.5	345-415Δ/600-720Y	13.3Δ/7.7Y	69	74	500	-240	260	RV-01/MF-16
	60	6.3	380-480Δ/660-720Y	13.3Δ/7.7Y		78	600	-210	200	RV-01/MF-16
2MV 740 H57	50	7.5	345-415Δ/600-720Y	16.7Δ/9.6Y	75	74	500	-240	320	RV-01/MF-16
	60	8.6	380-480Δ/660-720Y	17.3/10.0Y		78	600	-270	300	RV-01/MF-16

2MV series Selection diagram 50/60Hz difference

The performance curves of Manvac blower is tested through below ways: Under one atmospheric pressure suck 15°C air and then you can calculate the data of course allow 10% ,and when the sucked air and surrounding temperature are not higher than 25°C, you still can get total pressure difference as the curves shows.

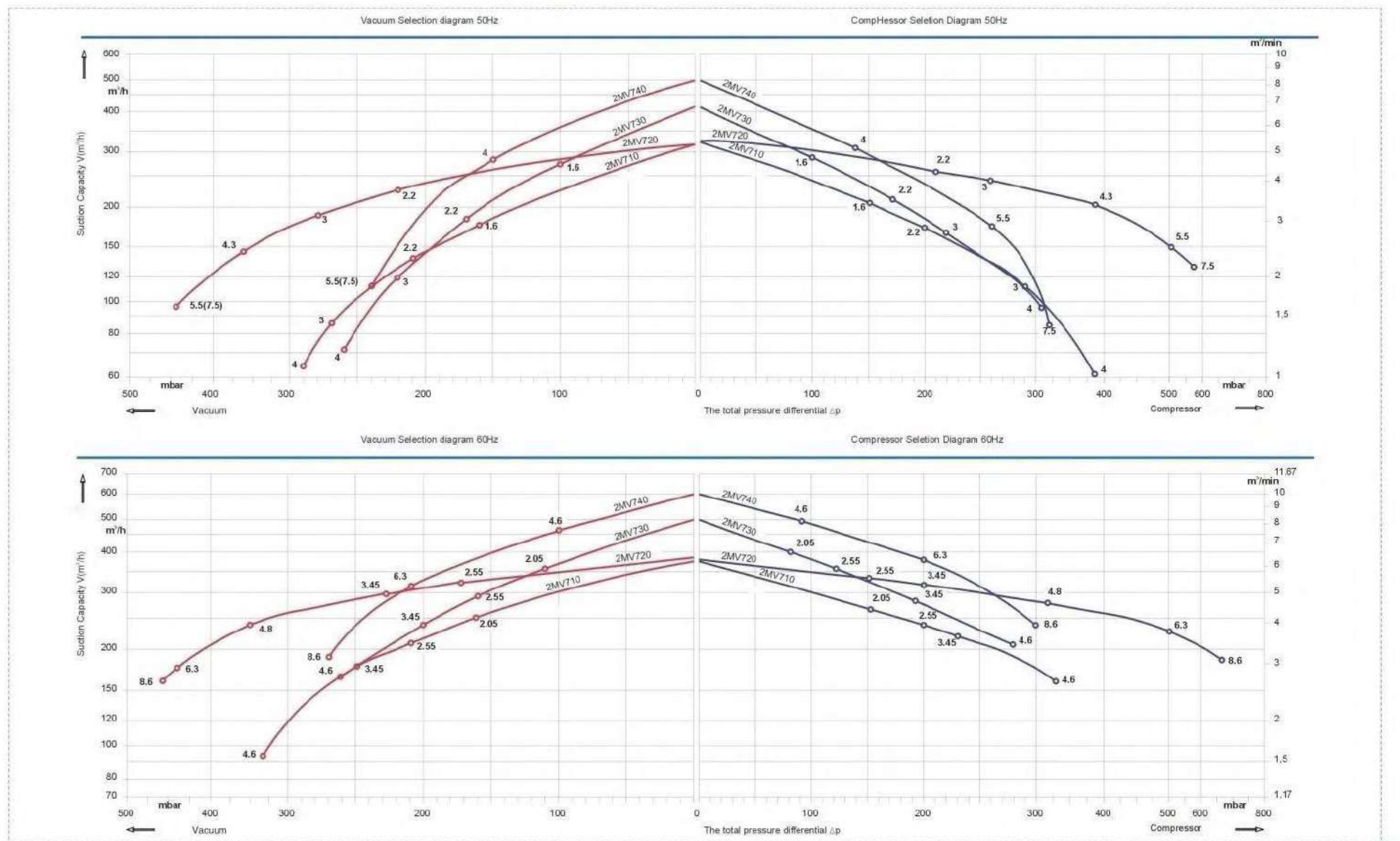

Selection and ordering data for side channel blowers in vacuum and pressure operation.

Three-phase blower

Order Number	Frequency Hz	MOTOR			Weight Kg	Sound db(A)	Normal airflow m ³ /h	Normal vacuum mbar	Normal pressure mbar	Discharging valve/ filter
		Rated								
		Output KW	Voltage V	Current A						
2MV 810 H07	50	4.0	345-415Δ/600-720Y	9.5Δ/5.5Y	54	70	530	-200	200	RV-01/MF-20
	60	4.6	380-480Δ/660-720Y	9.5Δ/5.5Y		74	620	-160	160	RV-01/MF-20
2MV 810 H17	50	5.5	345-415Δ/600-720Y	12.9Δ/7.4Y	63	70	530	-300	300	RV-01/MF-20
	60	6.3	380-480Δ/660-720Y	12.9Δ/7.45Y		74	620	-300	280	RV-01/MF-20
2MV 810 H27	50	7.5	345-415Δ/600-720Y	16.7Δ/9.6Y	66	70	530	-320	430	RV-01/MF-20
	60	8.6	380-485Δ/660-720Y	17.3Δ/10.0Y		74	620	-350	400	RV-01/MF-20
2MV 820 H17	50	5.5	345-415Δ/600-720Y	13.3Δ/7.7Y	83	74	520	-240	240	RV-01/MF-20
	60	6.3	380-480Δ/660-720Y	13.3Δ/7.7Y		78	620	-170	160	RV-01/MF-20
2MV 820 H27	50	7.5	345-415Δ/600-720Y	16.7Δ/9.6Y	86	74	520	-400	400	RV-02/MF-20
	60	8.6	380-480Δ/660-720Y	17.3Δ/10.0Y		78	620	-360	330	RV-02/MF-20
2MV 820 H37	50	11.0	345-415Δ/600-720Y	28.0Δ/16.2Y	104	74	520	-430	600	RV-02/MF-20
	60	12.6	380-480Δ/660-720Y	29.0Δ/16.7Y		78	620	-460	600	RV-02/MF-20
2MV 820 H47	50	15.0	345-415Δ/600-720Y	32.5Δ/18.8Y	120	74	520	-460	670	RV-02/MF-20
	60	17.3	380-480Δ/660-720Y	34.5Δ/19.9Y		78	620	-490	750	RV-02/MF-20
2MV 830 H07	50	4.0	345-415Δ/600-720Y	9.5Δ/5.5Y	57	70	700	-150	140	RV-01/MF-20
	60	4.6	380-480Δ/660-720Y	9.5Δ/5.5Y		74	840	-90	90	RV-01/MF-20
2MV 830 H17	50	5.5	345-415Δ/600-720Y	12.9Δ/7.4Y	66	70	700	-200	180	RV-01/MF-20
	60	6.3	380-480Δ/660-720Y	12.9Δ/7.45Y		74	840	-180	180	RV-01/MF-20
2MV 830 H27	50	7.6	345-415Δ/600-720Y	16.7Δ/9.6Y	69	70	700	-270	260	RV-01/MF-20
	60	8.6	380-480Δ/660-720Y	17.3Δ/10.0Y		74	840	-270	260	RV-01/MF-20
2MV 840 H27	50	7.5	345-415Δ/600-720Y	16.7Δ/9.6Y	91	74	900	-200	180	RV-01/MF-20
	60	8.6	380-480Δ/660-720Y	17.3Δ/10.0Y		78	1050	-150	120	RV-01/MF-20
2MV 840 H37	50	11.0	345-415Δ/600-720Y	28.0Δ/16.2Y	110	74	900	-280	370	RV-01/MF-20
	60	12.6	380-480Δ/660-720Y	29.0Δ/16.7Y		78	1050	-310	350	RV-01/MF-20

2MV series Selection diagram 50/60Hz difference

The performance curves of Manvac blower is tested through below ways: Under one atmospheric pressure suck 15°C air and then you can calculate the data of course allow 10% ,and when the sucked air and surrounding stempere are not higher than 25°C, you still can get total pressure difference as the curves shows.

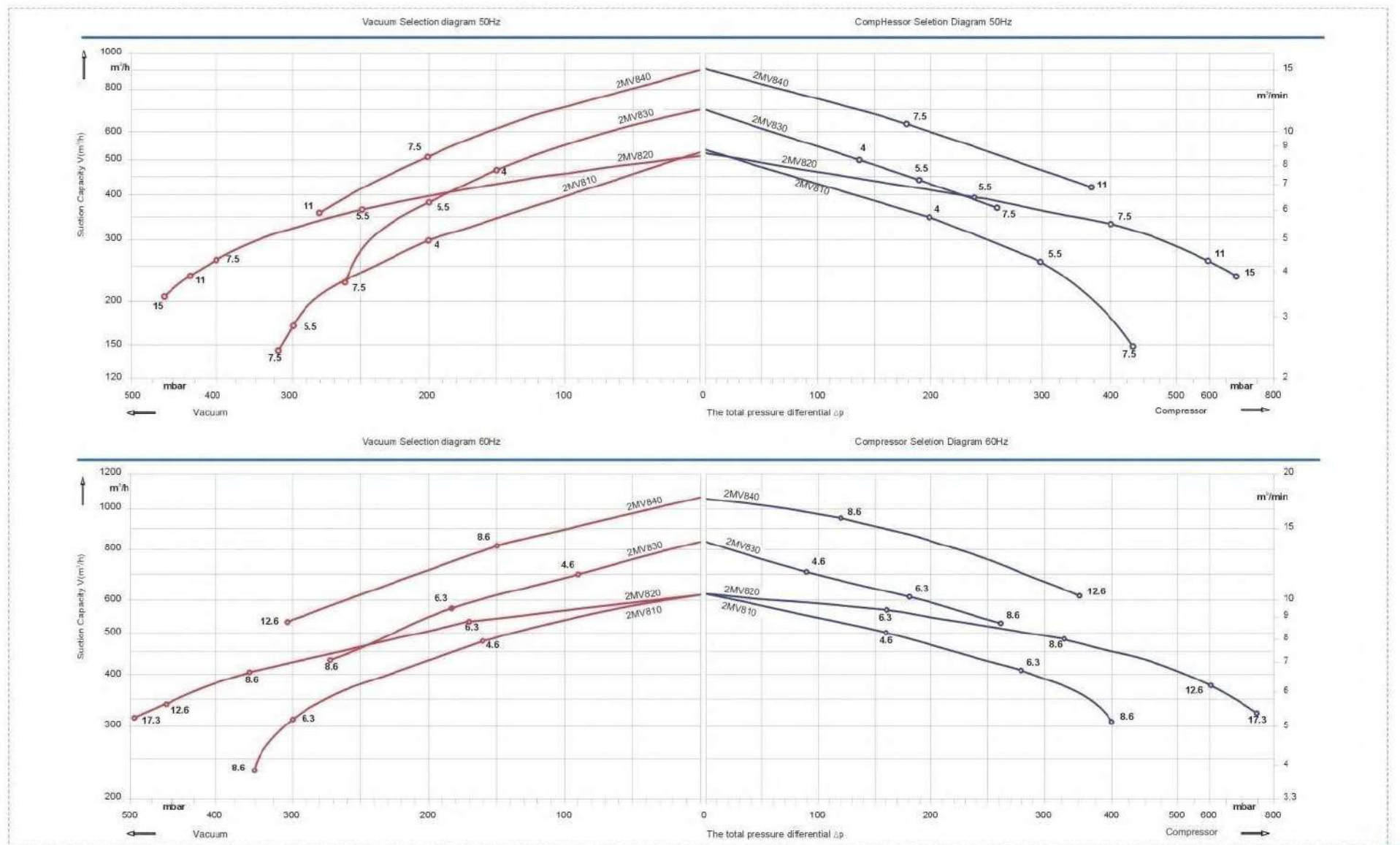

Selection and ordering data for side channel blowers in vacuum and pressure operation.

Three-phase blower

Order Number	Frequency	MOTOR			Weight	Sound	Normal airflow	Normal vacuum	Normal pressure	Discharging valve/ filter
		Output	Rated							
			Voltage	Current						
Hz	KW	V	A	Kg	db(A)	m ³ /h	mbar	mbar		
2MV 910 H07	50	8.5	345-415Δ/600-720Y	18.2Δ/10.5Y	93	74	1050	-210	210	RV-01/MF-32
	60	9.8	380-480Δ/660-720Y	18.2Δ/10.5Y		79	1250	-180	180	RV-01/MF-32
2MV 910 H17	50	12.5	345-415Δ/600-720Y	28.0Δ/16.2Y	116	74	1050	-280	270	RV-01/MF-32
	60	14.5	380-480Δ/660-720Y	29.0Δ/16.7Y		79	1250	-270	260	RV-01/MF-32
2MV 910 H37	50	18.5	345-415Δ/600-720Y	37.0Δ/21.0Y	126	74	1050	-340	460	RV-02/MF-32
	60	21.3	380-485Δ/660-720Y	39.0Δ/22.5Y		79	1250	-380	420	RV-02/MF-32
2MV 920 H17	50	12.5	345-415Δ/600-720Y	28.0Δ/16.2Y	187	74	1110	-300	370	RV-01/MF-32
	60	14.5	380-480Δ/660-720Y	29.0Δ/16.7Y		78	1310	-220	200	RV-01/MF-32
2MV 920 H27	50	16.5	345-415Δ/600-720Y	35.0Δ/20.0Y	197	74	1110	-410	370	RV-02/MF-32
	60	19.0	380-480Δ/660-720Y	36.5Δ/21.0Y		78	1310	-340	300	RV-02/MF-32
2MV 920 H37	50	20.0	345-415Δ/600-720Y	40.0Δ/23.0Y	204	74	1110	-440	500	RV-02/MF-32
	60	23.0	380-480Δ/660-720Y	42.0Δ/24.2Y		78	1310	-440	430	RV-02/MF-32
2MV 920 H47	50	25.0	345-415Δ/600-720Y	52.0Δ/30.0Y	211	74	1110	-440	590	RV-02/MF-32
	60	29.0	380-480Δ/660-720Y	52.0Δ/30.0Y		78	1310	-440	540	RV-02/MF-32
2MV 930 H07	50	8.5	345-415Δ/600-720Y	18.2Δ/10.5Y	98	75	1370	-120	110	RV-01/MF-32
	60	9.8	380-480Δ/660-720Y	18.2Δ/10.5Y		80	1650	-80	70	RV-01/MF-32
2MV 930 H17	50	12.5	345-415Δ/600-720Y	28.0Δ/16.2Y	121	75	1370	-210	190	RV-01/MF-32
	60	14.5	380-480Δ/660-720Y	29.0Δ/16.7Y		80	1650	-170	160	RV-01/MF-32
2MV 930 H37	50	18.5	345-415Δ/600-720Y	37.0Δ/21.0Y	131	75	1370	-310	320	RV-01/MF-32
	60	21.3	380-480Δ/660-720Y	39.0Δ/22.5Y		80	1650	-300	280	RV-01/MF-32
2MV 940 H27	50	15.0	345-415Δ/600-720Y	35.0Δ/20.0Y	187	75	1940	-130	110	RV-01/MF-32
	60	17.5	380-480Δ/660-720Y	36.5Δ/21.0Y		84	2310	-60	40	RV-01/MF-32
2MV 940 H37	50	20.0	345-415Δ/600-720Y	40.0Δ/23.0Y	212	75	1940	-220	200	RV-01/MF-32
	60	23.0	380-480Δ/660-720Y	42.0Δ/24.2Y		84	2310	-160	130	RV-01/MF-32
2MV 940 H47	50	25.0	345-415Δ/600-720Y	52.0Δ/30.0Y	219	75	1940	-310	270	RV-01/MF-32
	60	29.0	380-480Δ/660-720Y	52.0Δ/30.0Y		84	2310	-270	220	RV-01/MF-32
2MV 943 H27	50	15.0	345-415Δ/600-720Y	35.0Δ/20.0Y	220	75	2050	-160	170	RV-01/MF-32
	60	17.5	380-480Δ/660-720Y	36.5Δ/21.0Y		84	2480	-110	120	RV-01/MF-32
2MV 943 H37	50	20.0	345-415Δ/600-720Y	40.0Δ/23.0Y	230	75	2050	-250	230	RV-01/MF-32
	60	23.0	380-480Δ/660-720Y	42.0Δ/24.2Y		84	2450	-190	180	RV-01/MF-32
2MV 943 H47	50	25.0	345-415Δ/600-720Y	52.0Δ/30.0Y	235	75	2330	-310	270	RV-01/MF-32
	60	29.0	380-480Δ/660-720Y	52.0Δ/30.0Y		84	2330	-270	230	RV-01/MF-32

2MV series Selection diagram 50/60Hz difference

The performance curves of Manvac blower is tested through below ways: Under one atmospheric pressure suck 15°C air and then you can calculate the data of course allow 10%, and when the sucked air and surrounding temperature are not higher than 25°C, you still can get total pressure difference as the curves shows.

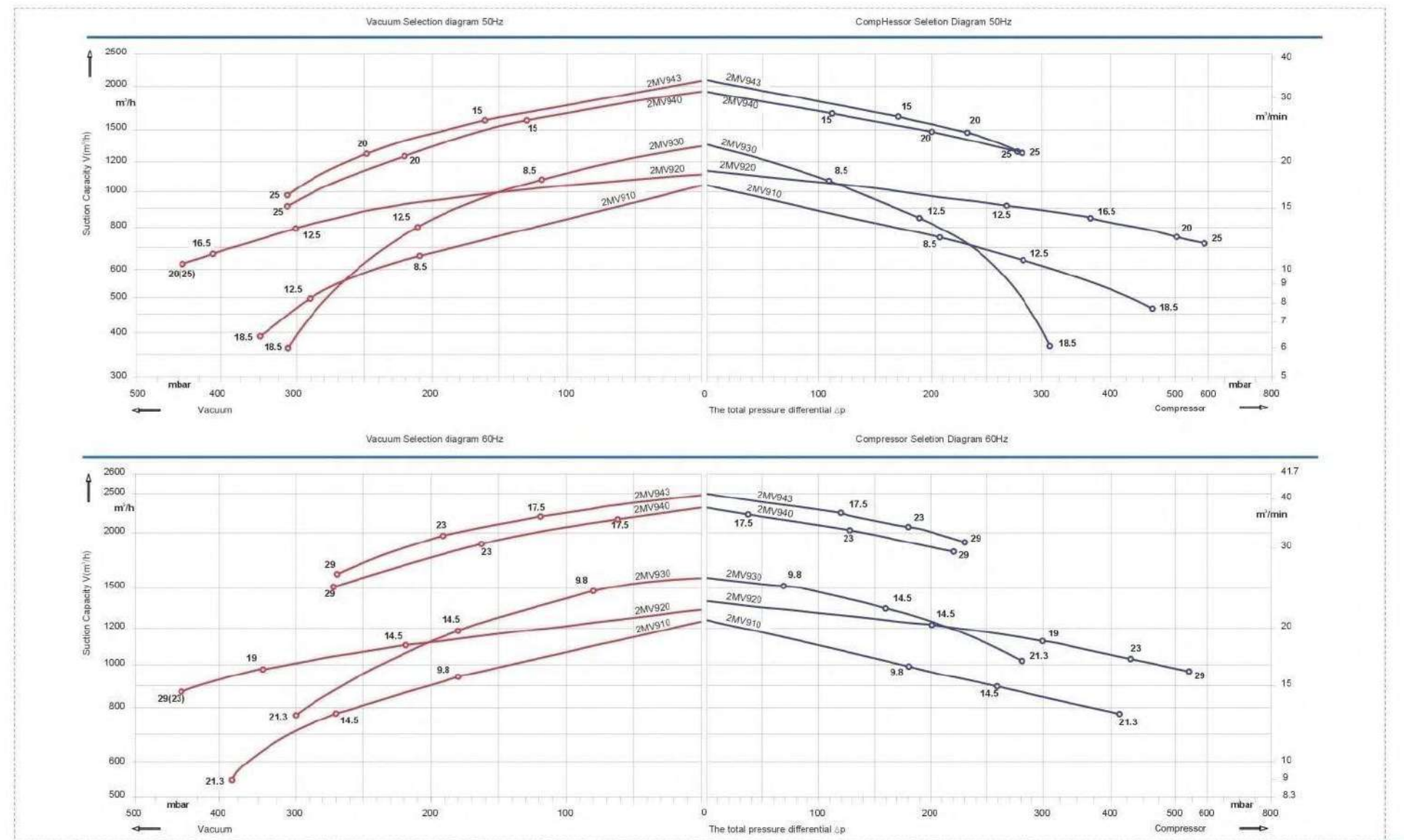

Dimensions[mm]

2MV 210./2MV 230./2MV 410./2MV 430./2MV 490.

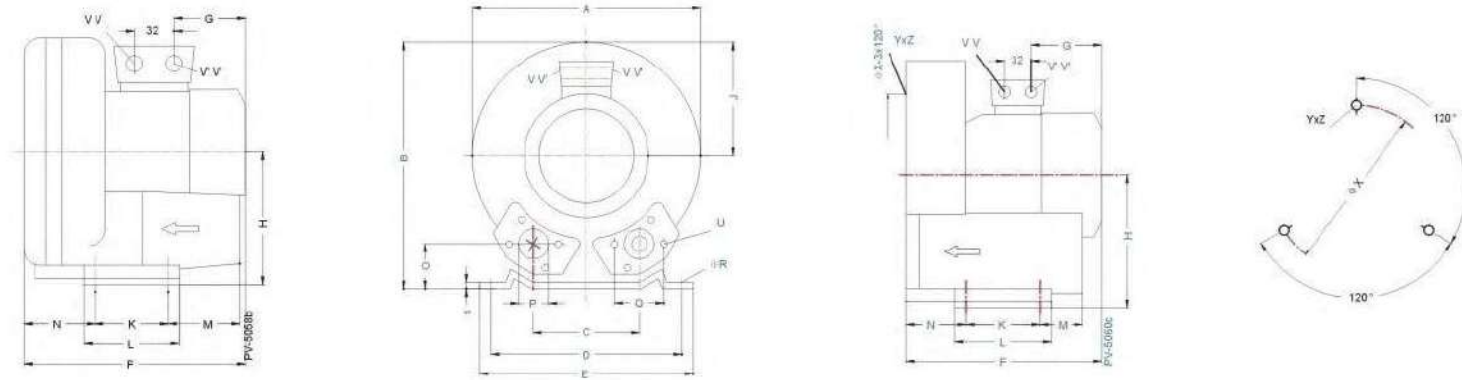

Type	Phases																X-Holes										
		A	B	C	D	E	F	G	H	J	K	L	M	N	O	P	Q	R	S	U	V(1~)	V'(1~)	V(3~)	V'(3~)	YxZ	X	
2MV 210 H06	3~	246	247	90	205	230	219	92	128	101	83	108	75	71	39	G1...(150ef-deep)	64	10	2.5	M6x17			M25x1.5	M16x1.5	M6x15	0°/120°/240°	140
2MV 210 H16	3~																										
2MV 230 H06	3~						242	102		101					84												
2MV 230 H16	3~						269	128		111																	
2MV 230 H26	3~																										
2MV 310 H06	3~	268	272	93			260	135	141				62	69	41											159.8	
2MV 310 H16	3~																										
2MV 330 H06	1~						276								85						M16x1.5	M25x1.5					
2MV 330 H16	3~																										

Note: 1.The Catalogue only for reference, If there are differences, please confirm by the practicalities.
2.The specifications are subject to change by the manufacturer without prior notice.

2MV 410./2MV 430./2MV 490.

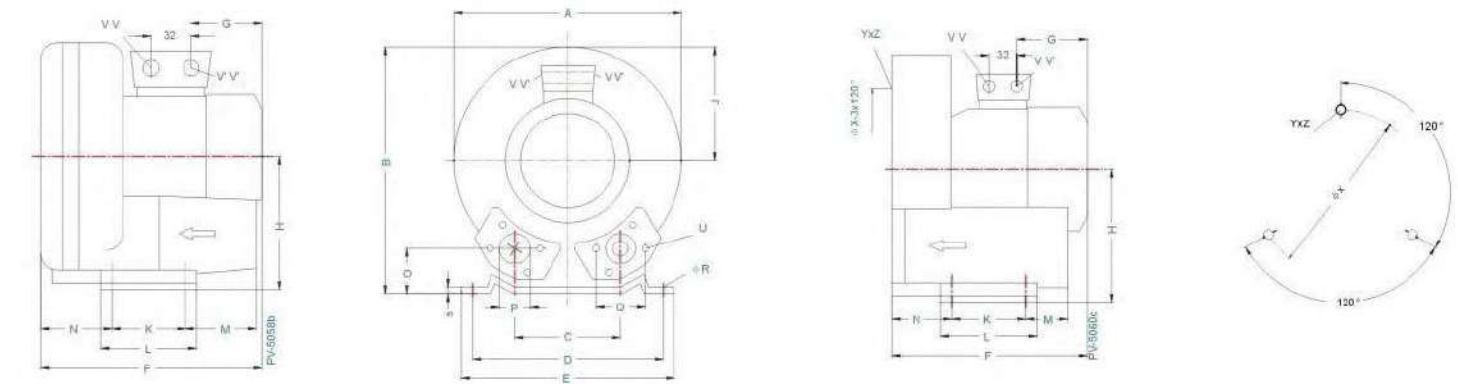

Type	Phases																X-Holes										
		A	B	C	D	E	F	G	H	J	K	L	M	N	O	P	Q	R	S	U	V(1~)	V'(1~)	V(3~)	V'(3~)	YxZ	X	
2MV 410 H16	3~						292	153		120																	
2MV 410 H26	3~																										

Note: 1.The Catalogue only for reference, If there are differences, please confirm by the practicalities.
2.The specifications are subject to change by the manufacturer without prior notice.

Dimensions[mm]

2MV 220./2MV 420.

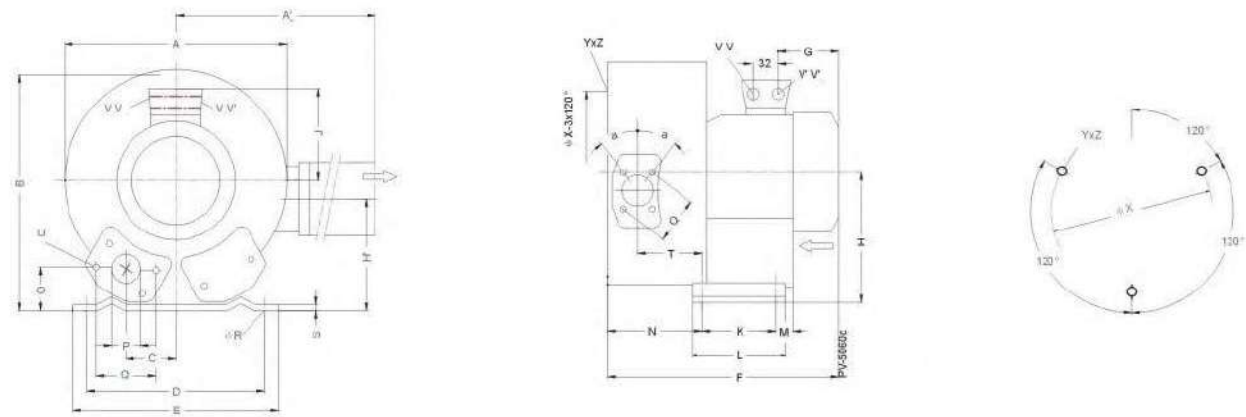

Type	Phases																					X-Holes													
		A	A'	B	C	D	E	F	G	H	H'	J	K	L	M	N	O	P	Q	R	S	T	U	V(1~)	V'(1~)	V(3~)	V'(3~)	α	X	YxZ	α	X	W		
2MV 420 H36	3~	321	321	315	58	225	255	461	185	154	154	128	95	130	70	151	46	G1... (150ef-deep)	72	12	3	106	M8x19		M25x1.5	M16x1.5		28°	174						
2MV 420 H46	3~																																		

Note: 1. The Catalogue only for reference, If there are differences, please confirm by the practicalities.
2. The specifications are subject to change by the manufacturer without prior notice.

2MV 510./2MV 530./2MV 590.

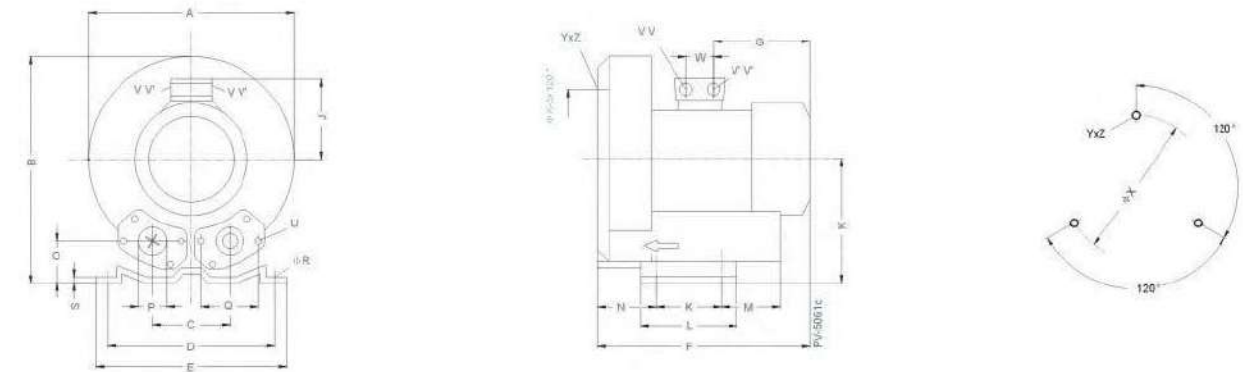

Type	Phases																					X-Holes													
		A	B	C	D	E	F	G	H	J	K	L	M	N	O	P	Q	R	S	U	V(1~)	V'(1~)	V(3~)	V'(3~)	YxZ	α	X	W							
2MV 510A21	1~	334	337	120	290	295	345	198	175	128	115	155	96	87	48	55	83	14	4	M8x17	M16x1.5	M25x1.5			M8x20	0°/120°/240°	200	32							
2MV 510 H06	3~						314	153		120															M25x1.5	M16x1.5									
2MV 510 H16	3~																																		
2MV 510 H26	3~						346	185		128																									
2MV 510 H36	3~																																		
2MV 530A11	1~							371	188	175	128										M16x1.5	M25x1.5													
2MV 530 H06	3~							338	152	174	120														M25x1.5	M16x1.5									
2MV 530 H16	3~																																		
2MV 530 H26	3~							371	184		128																								
2MV 530 H36	3~																																		

Note: 1. The Catalogue only for reference, If there are differences, please confirm by the practicalities.
2. The specifications are subject to change by the manufacturer without prior notice.

Dimensions[mm]

2MV 610./2MV 710./2MV 730./2MV 790

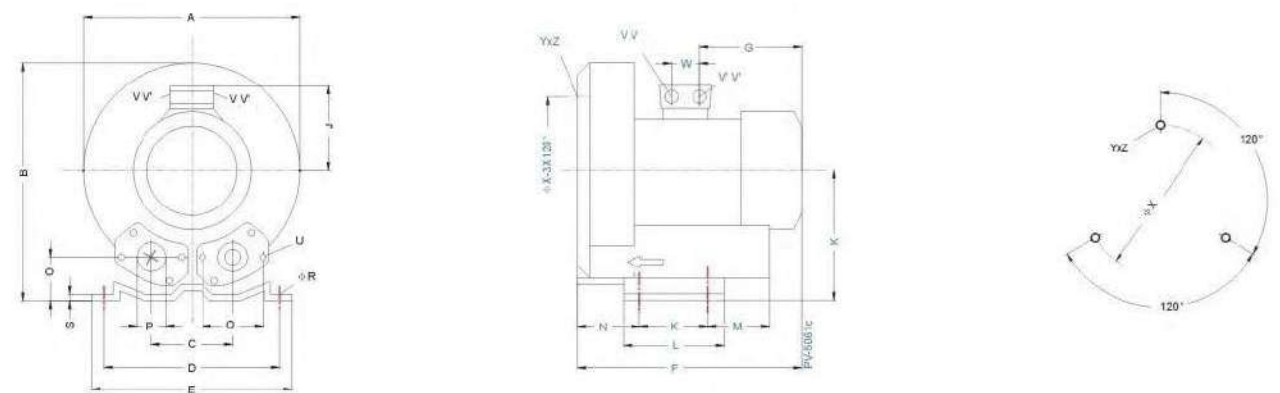

Type	Phases																		X-Holes									
		A	B	C	D	E	F	G	H	J	K	L	M	N	O	P	Q	R	S	U	V(1-)	V'(1-)	V(3-)	V'(3-)	YxZ	X	W	
2MV 610H06	3~	360	366	122	284	325	354	185	192	128	140	180	64	74	56	56	93	13	4.5	M8x17			M25x1.5	M16x1.5	M8x20	0°/120°/240°	226	29
2MV 610 H16	3~																											
2MV 610 H26	3~						365	188		135																		42
2MV 710A11	1~	382	384	125	290		377	185	198	128			84	10R	54	55	83	15			M25x1.5	M15x1.5			M10x20		240	32
2MV 710 H06	3~																						M25x1.5	M16x1.5				
2MV 710 H16	3~																											
2MV 710 H26	3~						411	190		135											M32x1.5	M32x1.5	M32x1.5	M32x1.5				42
2MV 710 H37	3~						452	211		148																		
2MV 730 H06	3~	381	420				385	184	197	128																		
2MV 730 H16	3~																											
2MV 730 H26	3~						419	189		135																		
2MV 730 H37	3~						440	210		148																		

Note: 1. The Catalogue only for reference, if there are differences, please confirm by the practicalities.
2. The specifications are subject to change by the manufacturer without prior notice.

2MV 520.
2MV 720...4.
...5.

2MV 520.
2MV 720...1.
...2.
...3.

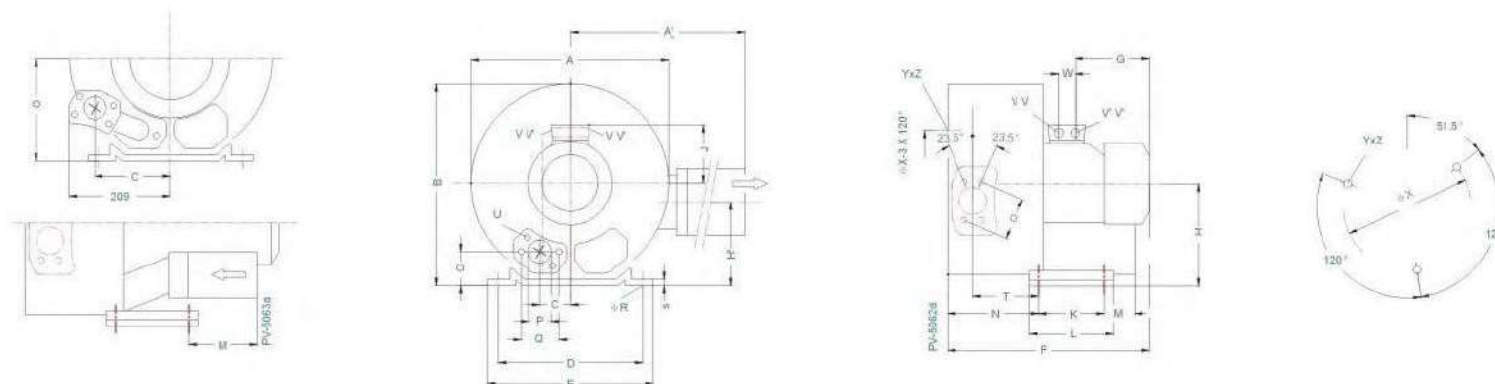

Type	Phases																		X-Holes												
		A	A'	B	C	D	E	F	G	H	H'	J	K	L	M	N	O	P	Q	R	S	T	U	V	V'	V''	V'''	X	YxZ	W	
2MV 520 H46	3~	372	411	371	60	260	295	465	190	175	144	135	115	155	98	171	48	55	83	14	4	116	M8x17	4xM32x1.5				200	M8x20	51.5°/171.5°/291.5°	42
2MV 520 H57	3~							499	224																						
2MV 720 H16	3~	426	424	420	63	290	325	473	185	196	164	128	140	180	94	205	54				15	4.5	129	M25x1.5	M16x1.5		240	M10x20		32	
2MV 720 H26	3~							507	190			135																			
2MV 720 H37	3~							528	211			148																			
2MV 720 H47	3~				154	290		570	225			167			225	94															
2MV 720 H57	3~																														

Note: 1. The Catalogue only for reference, if there are differences, please confirm by the practicalities.
2. The specifications are subject to change by the manufacturer without prior notice.

Dimensions[mm]

2MV 740-...4.
-...5.

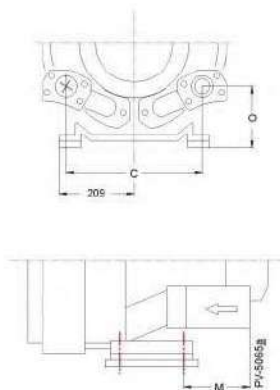

2MV 740-...3.

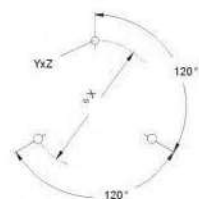
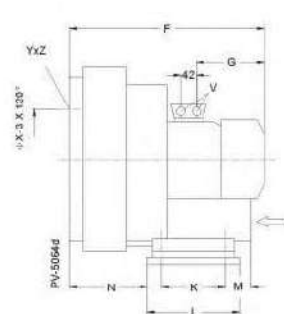
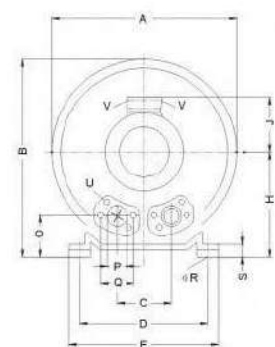

Type	Phases																				X-Holes				
		A	B	C	C'	D	E	F	G	H	J	K	L	M	N	O	P	Q	R	S		U	V	X	YxZ
2MV 740H37	3~	424	430	125		290	325	528	211	218	148	140	188	84	205	74	55	83	15	24.5	M8x17	4xM32x1.5	240	M10x20	0°/120°/240°
2MV 740H47	3~	334			309			569	224		167														
2MV 740H57	3~																								

Note: 1. The Catalogue only for reference, if there are differences, please confirm by the practicalities.
2. The specifications are subject to change by the manufacturer without prior notice.

2MV 810/2MV 830.

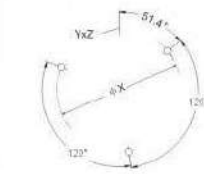
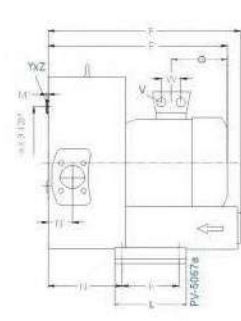
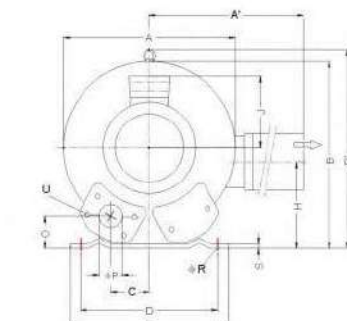
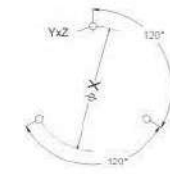
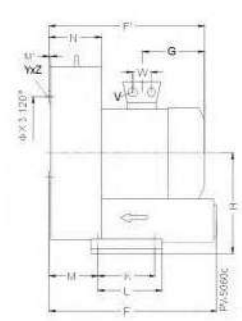
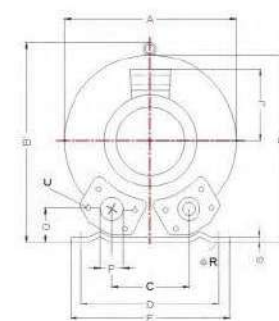

Type	Phases																											X-Holes
		A	A'	B	B'	C	D	E	F	F'	G	H	J	K	L	M	M'	N	N'	O	P	R	S	V	W	X	YxZ	
2MV 810H07	3~	481		461	509	162	356	394	433	450	230	240	148	170	217	124	2	149		65	G2...	15	6	4xM32x1.5	42	286	M10x35	0°/120°/240°
2MV 810H17	3~									477	247		167															
2MV 810H27	3~																											
2MV 820H17	3~	500	349	490	509	76			545	589		199												236	84			51.4°/171.4°/291.4°
2MV 820H27	3~																											
2MV 820H37	3~									694	318		197												4xM40x1.5	54		
2MV 820H47	3~																											
2MV 830H07	3~	481		461	509	162			449	496	230	240	148		129		184		85						4xM32x1.5	42		0°/120°/240°
2MV 830H17	3~									492	247		167															
2MV 830H27	3~																											

Note: 1. The Catalogue only for reference, if there are differences, please confirm by the practicalities.
2. The specifications are subject to change by the manufacturer without prior notice.

Dimensions[mm]

2MV 840-...37

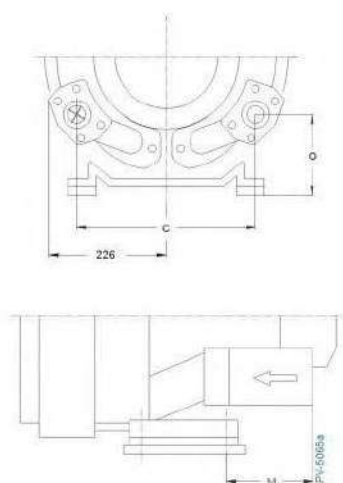

2MV 840-...27

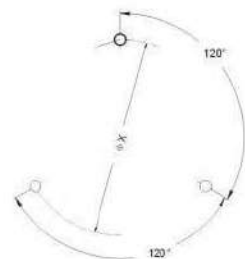
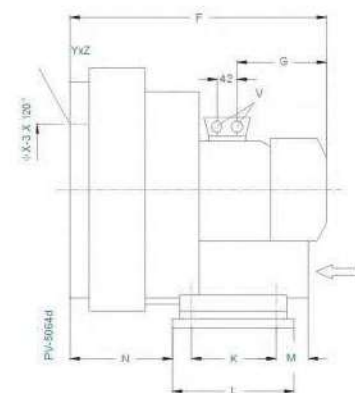
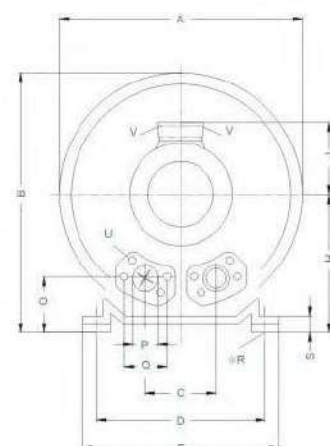

Type	Phases	A	B	C	C'	D	E	F	G	H	J	K	L	M	N	O	P	R	S	V	W	X	YxZ	X-Holes
2MV 840 H27	3~	500	550		336	356	394	589	247	300	167	170	217		261	125	G2...	15	68	4xM32x1.5	42	288	M12x20	0°/120°/240°
2MV 840 H37	3~			336				694	318		197			312	212	165				4xM40x1.5	54			

Note: 1. The Catalogue only for reference, if there are differences, please confirm by the practicalities.
2. The specifications are subject to change by the manufacturer without prior notice.

2MV 910./930.

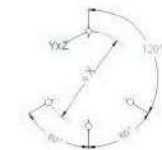
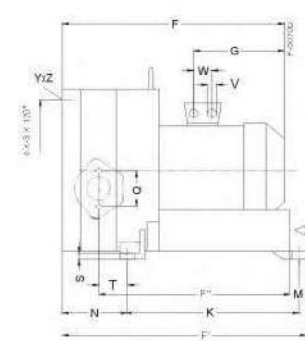
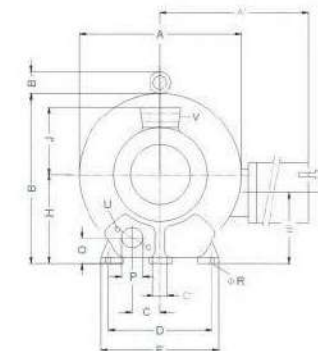
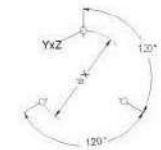
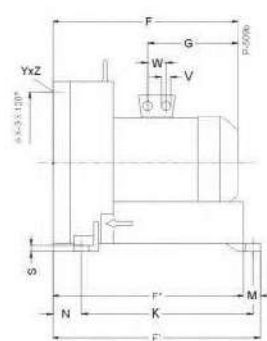
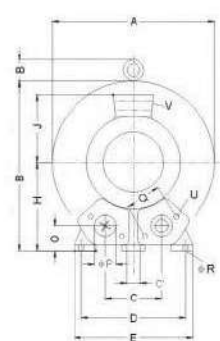

Type	Phases	A	B	B ₁	C	C'	D	E	F	F'	F''	G	H	J	K	M	N	O	P	Q	R	S	T	U	V	W	X	YxZ	X-Holes	
2MV 910 H07	3~	550	599	55	207	15	360	415	525	644	605	268	300	187	533	39	89	93	100	150	15	22	M12x35	4xM32x1.5	42	490	M12x30	0°/120°/240°		
2MV 910 H17	3~								611			345		197												4xM40x1.5	54			
2MV 910 H37	3~																													
2MV 930 H07	3~								563	663	643	490		187												4xM32x1.5	42			
2MV 930 H17	3~								639			345		197												4xM40x1.5	54			
2MV 930 H37	3~																													

Type	Phases	A	B	B ₁	C	C'	D	E	F	F'	F''	G	H	J	K	M	N	O	P	Q	R	S	T	U	V	W	X	YxZ	X-Holes		
2MV 920 H17	3~	615	608	55	103.5	19	360	415	752	786	634	345	300	197	533	39	230	93	100	150	15	22	104	M12x35	4xM40x1.5	54	499	M12x30	120°/160°/160°		
2MV 920 H27	3~																														
2MV 920 H37	3~																														
2MV 920 H47	3~																														

Note: 1. The Catalogue only for reference, if there are differences, please confirm by the practicalities.
2. The specifications are subject to change by the manufacturer without prior notice.

安装尺寸图 Dimensions[mm]

2MV 940.

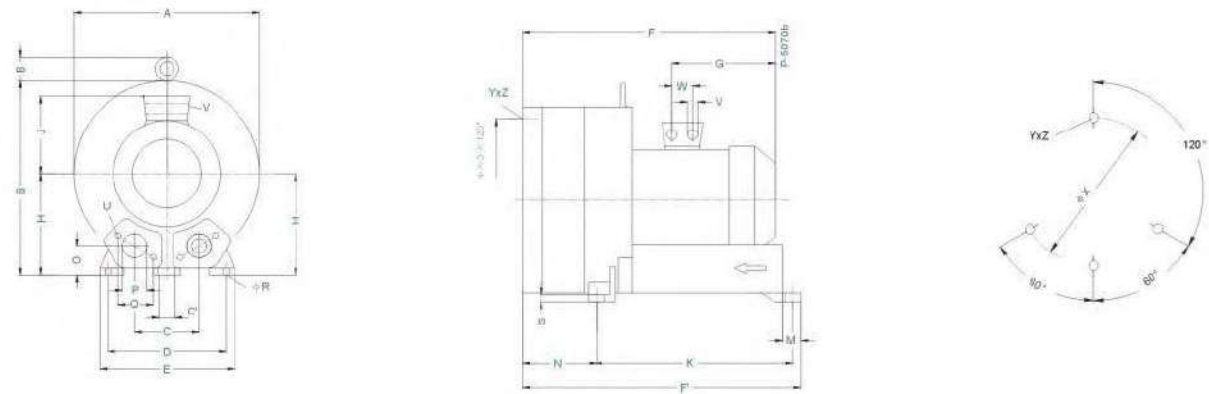

Type	Phases	A	B	B ₁	C	C'	D	E	F	F'	F''	G	H	J	K	M	N	O	P	Q	R	S	U	V	W	X	YxZ	X-Holes
2MV 940 H27	3~	615	606	52	207	15	360	415	790	824	601	345	300	197	533	39	280	93	100	140	15	22	M12x35	4xM32x1.5	54	490	M12x30	120°/60°/60°
2MV 940 H37	3~																											
2MV 940 H47	3~								X			X																

Note: 1. The Catalogue only for reference, if there are differences, please confirm by the practicalities.
2. The specifications are subject to change by the manufacturer without prior notice.

2MV 943.

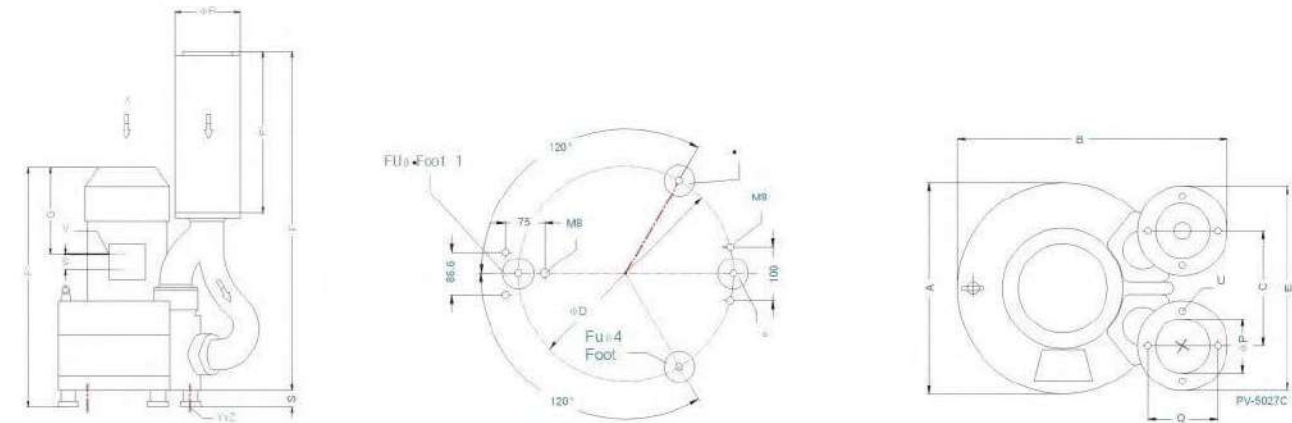

Type	Phases	A	B	C	D	E	F	F'	F''	G	P	P'	Q	S	U	V	W	YxZ
2MV 943 H27	3~	615	734	307	490	527	1225	790	600	291	220	130	190	40	M16x30	4xM40x1.5	54	M12x10.5
2MV 943 H37	3~																	
2MV 943 H47	3~																	

Note: 1. The Catalogue only for reference, if there are differences, please confirm by the practicalities.
2. The specifications are subject to change by the manufacturer without prior notice.



סכיני אוויר

Stainless steel air knife series



Outlet: 0.3-5mm Air knife length: 0.2-3m

- Widely used in circuit boards, plating parts, film drying
- All stainless steel SUS304 or 316L material, acid and alkali resist
- According to the aerodynamic principle design, wind resistance wind speed is average.
- Pressure can be 5kgf / cm², wind speed up to 400m / s, can blow hot air, temperature can be 250 °C
- Can be used for drying water, isolated curtain, water curtain, etc., To reduce the cold / hot air loss
- Inlet diameter: 1^{1/2}" / 1^{1/4}" / 2" / 2.5" / 3"

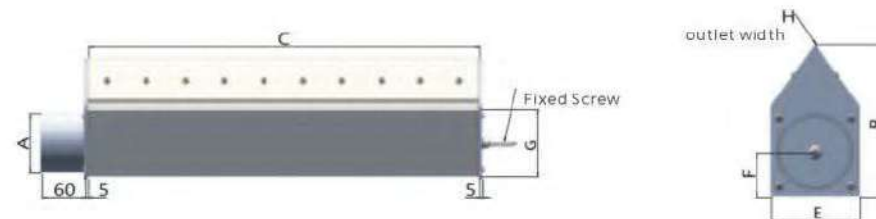

TYPE	A	B	C	D	E	F	G	H
JMSUS-32/38-C-H	32/38	104	100-2400	M8×50	50	25	49	0.3-5
JMSUS-45/51-C-H	45/51	120	100-2400	M8×50	60	28	63	0.3-5
JMSUS-60/63-C-H	57/63	142	100-2400	M8×50	77	38	82	0.5-5
JMSUS-76-C-H	76	155	100-2400	M8×50	89	45	86	0.5-5
JMSUS-89-C-H	89	188	100-2400	M10×50	100	50	81	1-5
JMSUS-108-C-H	108	253	100-2400	M10×50	128	63	110	1-8

Aluminum alloy air knife series



Outlet: 0.3-3mm Air knife length: 0.1-3m

- Cost-effective, space savings, easy installation
- Widely used in circuit boards, plating parts, film drying
- Small resistance, strong wind speed, uniform outlet
- The main body of aluminum alloy 6061 material stretch forming. The surface is treated by anticathode oxidation.
- Pressure can be 2kgf / cm², temperature can be 200 °C, can be connected to the heater blowing hot air

Inlet diameter: 2"

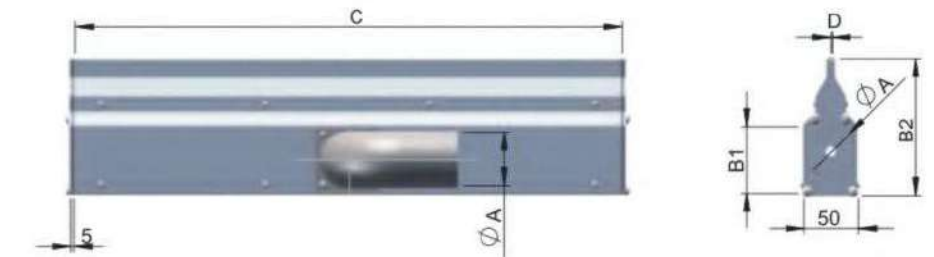

TYPE	A	B1	B2	C	D
JMAL-C-D-A	32/38/45/51	63	125	100-3000	0.2-3

Coanda effect air knife

- Adjustable width of the outlet (0.3-8mm)
- Anti-corrosion, anti-leakage design
- Widely used in circuit boards, plating parts, film drying
- Unique protruding knife edge, jet continuous, controllable airflow
- The droplet shape and the improved air entrainment design provide high-speed and stable airflow
- Inlet diameter: 3"

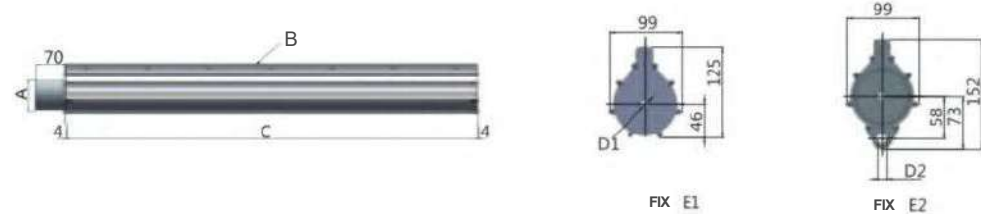

TYPE	A	B	C	D1	D2	FIX
JMKED-C-51-B	51	0.8-5	100-3000	M8	Φ12.5	E1/E2
JMKED-C-63-B	63	0.8-5	100-3000	M8	Φ12.5	E1/E2
JMKED-C-76-B	76	0.8-5	100-3000	M8	Φ12.5	E1/E2

Muffler



A	D(mm)	L(mm)
G2 _{1/2"}	78	60
G2"	62	60
G1 _{1/2"}	48	50
G1 _{1/4"}	40	50

Filtering barrels

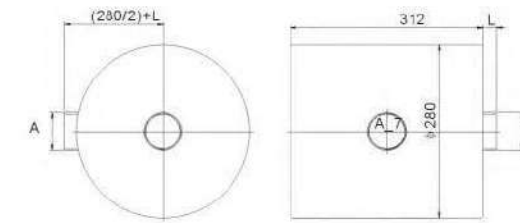

A	L(mm)
G2 _{1/2"}	65
G2"	50
G1 _{1/2"}	40
G1 _{1/4"}	32

Air filter

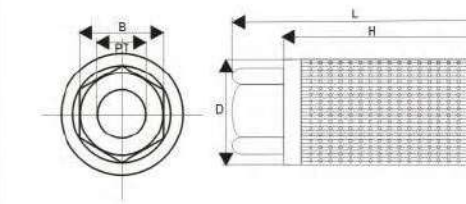

TYPE	PT	D (mm)	L (mm)	H (mm)	B (mm)	Traffic (l/min)	Weight (Kg)
MF-08	1	58	170	155	42	100	110
MF-10	1 1/4"	71	186	170	54	100	210
MF-12	1 1/2"	85	196	182	65	100	285
MF-16	2	103	215	202	75	100	395
MF-20	2 1/2"	148	274	252	97	100	750
MF-32	4	208	380	357	142	100	1000

Pressure relief valve

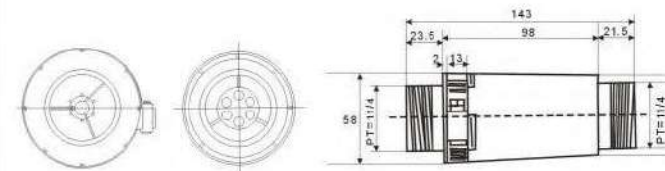

TYPE	PT	L (mm)	PRESSURE
RV-01	1 1/4"	143	0-300mbar
RV-02	1 1/4"	143	300-800mbar

אנו זמינים לכל שאלה או בקשה
בטלפון או בדוא"ל

סניף צפון - 052-6915111,
קיבוץ כפר בלום 1215000
סניף מרכז/דרום - 07-37870729
ניצני עוז 27, ערוגות

אתר www.airms.co.il

דוא"ל Info@airms.co.il

